

RESTAURANT SERIES STOCK POT RANGES



BPSP-18-2

Restaurant Series Stock Pot Ranges

The Restaurant Series Stockpot Ranges feature stainless steel front, sides & cabinet base, durable, cool to the touch knobs, heavy-duty top grates with full drip pans, 90,000-210,000 BTU burners and heavy-duty castings, with sloping design to remove spills.

Standard Features

- Stainless steel front, cabinet and bottom
- Three-ring burner with two adjustable gas valves provides flexibility and maximum 90,000 BTU/hr; or with three adjustable valves for 105,000 BTU/hr
- Burner is equipped with two continuous pilots for instant ignition
- Roll front is easy to load and gradual slope design reduces spill over
- Heavy-duty cast iron top grate removes easily for cleaning
- Durable stainless steel cabinet base provides additional storage
- Chrome plated 6" legs with adjustable feet

Options & Accessories

- 18" Height available
- Casters
- Quick disconnect and flexible gas hose
- Wok attachment
- 3 Valves / 3 Ring Burner
- Jet Burner

Applications

Soups; Sauces; Stocks; Pasta; Schools; Contract Feeders

Certifications



RESTAURANT SERIES STOCK POT RANGES

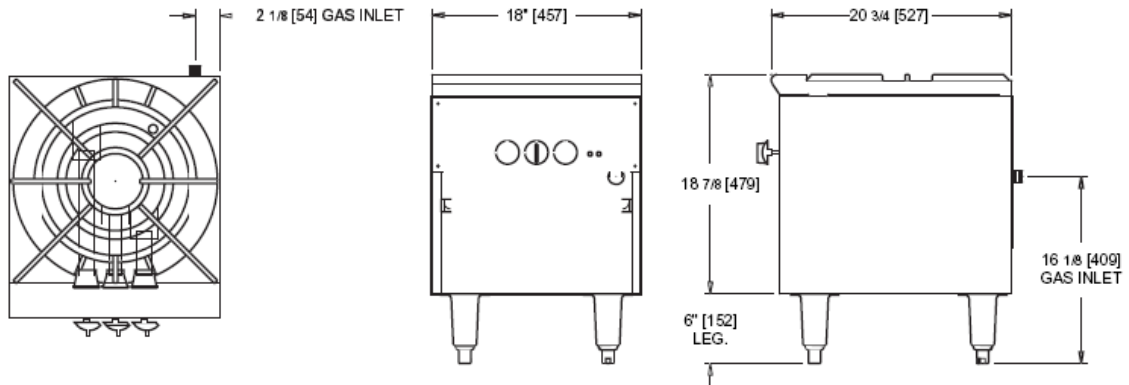

PRODUCT SPECIFICATIONS

Clearance: For use only on non-combustible surfaces. Legs or stands are required for non-combustible floors; or 2 over-hang is required when curb mounted. Provide 0" clearance from non-combustible surfaces and 4" from back, 10" from sides from combustible surfaces.

Gas Information:

Manifold pressure is 5.0"W.C. or natural gas or 10.0" for propane gas. Manifold size is 3/4" NPT. 3/4" pressure regulator supplied with equipment to be installed at time of connection.

Must specify type of gas and elevation if over 2000 ft. when ordering.

BPSP-18-2: 18W X 21D X 24H; 3 Ring, 2 Valves; 90, 000 BTU, 130 Lbs
BPSP-18-3: 18W X 21D X 24H; 3 Ring, 3 Valves; 105, 000 BTU, 135 Lbs
BPSP-18-2-D: 18W X 42D X 24H; 2 Units, 2 Valves; 180, 000 BTU, 255 Lbs
BPSP-18-3-D : 18W X 42D X 24H; 2 Units, 3 Valves; 210, 000 BTU, 260 Lbs
BPSP-36-2-D: 36W X 21D X 24H; 2 Units, 2 Valves; 180, 000 BTU, 255 Lbs
BPSP-36-3-D: 36W X 21D X 24H; 2 Units, 3 Valves; 210, 000 BTU, 265 Lbs

Freight Class: 85

FOB: Standex Dock