



## SUPERDECK SERIES 7.5" DECK HEIGHT BRICK-LINED GAS PIZZA OVENS

### SERIES: Y-BL



Bakers Pride® Y-BL series deck ovens are the best-selling pizza ovens in the world. Each oven chamber features a Cordierite brick-lined ceiling and Lightstone fibrament deck with an 7.5" deck height. The Independently controlled top and bottom heat dampers ensure perfectly balanced results. Choose from two different deck areas and overall oven widths (78" or 84") to suit your needs.

This series is constructed with heavy-duty, .25" angle iron frame, which is fully welded to allow for double-stacking. Oven exteriors are all heavy-duty stainless steel and are fully insulated for cooler outer temperatures and consistent interior temperatures.

Options are available to accommodate the configuration of your kitchen, such as side-mounted controls and special-height legs.

#### FEATURES AT A GLANCE

- 120,000 total BTUH with natural or LP gas
- 300–650°F (148–343°C) temperature range
- Choose deck area: 60" x 36" (1524 x 914 mm) or 66" x 44" (1676 x 1118 mm)
- Choose overall width: 78" or 84"
- 2" (51 mm) thick Lightstone fibrament, brick-lined decks
- 7.5" (191 mm) deck height
- Stackable
- Combination gas controls with valve, regulator, and pilot safety
- Independently controlled top and bottom heat dampers
- Front- or side-mounted gas controls with valve, regulator, and pilot safety
- Heavy-duty, slide-out flame diverters
- All stainless steel exteriors, aluminized steel interiors
- Spring-balanced, fully insulated doors
- Left-side or rear 3/4" (19 mm) NPT gas connection
- Heavy-duty steel legs finished with durable Bakertone
- Fully insulated throughout
- Two-year limited warranty

#### OPTIONS & ACCESSORIES

- Stainless steel leg covers (per pair)
- Special-height legs (per set of four)
- 150–550°F (65–287°C) bake thermostat
- Draft flue for direct vent (not available on CE units)
- Automatic oven starter
- Side-mounted controls (Specify when ordering.)
- Deck brush and scraper (48" (1219 mm) long with wood handle)
- Stainless steel wood chip box
- Legs with casters
- Cordierite or steel decks



# SUPERDECK SERIES 7.5" DECK HEIGHT BRICK-LINED GAS PIZZA OVENS

## SERIES: Y-BL

### EQUIPMENT DIMENSIONS

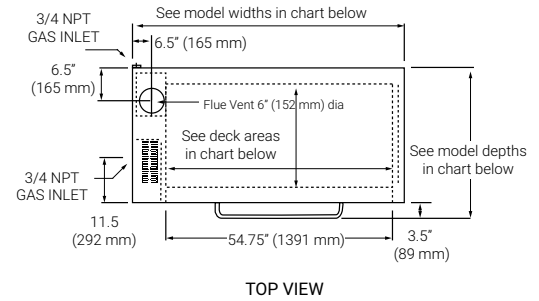
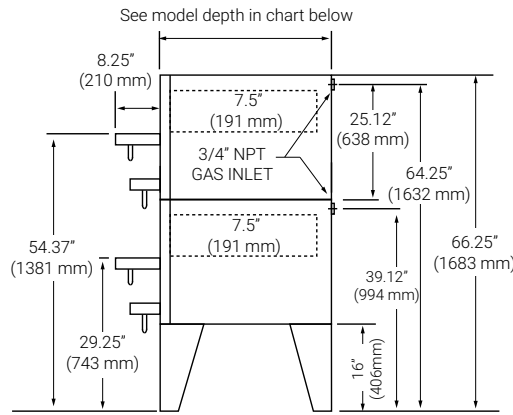
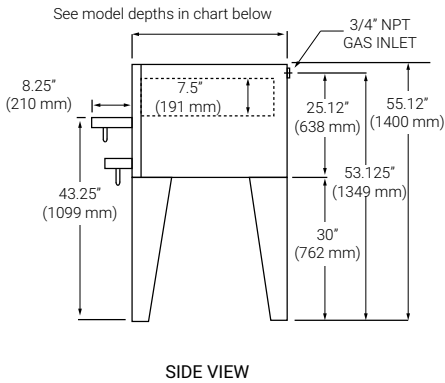

### MECHANICAL SPECIFICATIONS

Model #	Overall Dim** (W x H x D)	Total BTUH***	kW***	Deck Height	Deck Size	Decks	Baking Chambers	Thermostat Range	Carton Dim (W x H x D)	Cubic Feet	Cubic Meter	Ship Wt. • (kg)
Y-600BL	78" x 55.12" x 43" (1981 x 1400 x 1092)	120,000	35.15	7.5" (191)	60" x 36" (1524 x 914)	1	1	300°-650°F (149-343°C)	31" x 82" x 53" (787 x 2083 x 1364)	76	2.4	1338 (607kg)
Y-602BL	78" x 66.25" x 43" (1981 x 1683 x 1092)	240,000	70.3	7.5" (191)	60" x 36" (1524 x 914)	2	2	300°-650°F (149-343°C)	*	*	*	2676 (1214kg)
Y-800BL	84" x 55.12" x 51" (2134 x 1400 x 1295)	120,000	35.15	7.5" (191)	66" x 44" (1676 x 1118)	1	1	300°-650°F (149-343°C)	31" x 86" x 60" (787 x 2184 x 1524)	78	2.8	1542 (699kg)
Y-802BL	84" x 66.25" x 51" (2134 x 1683 x 1295)	240,000	70.3	7.5" (191)	66" x 44" (1676 x 1118)	2	2	300°-650°F (149-343°C)	*	*	*	3084 (1399kg)

\*Each oven ships in separate carton as do the legs. Refer to the single unit for carton specs. Shipping weight shown includes all decks and legs.

\*\*Height includes 30" (762 mm) legs on single units and 16" (406 mm) on stacked units.

\*\*\*CE certification not available in LP gas

### GAS CONNECTIONS

3/4"  
CE certification not available with LP gas  
Each deck requires a separate gas connection

### REQUIRED CLEARANCES

	Non-Combustible Construction	Combustible Construction
Left	0" (0 mm)	1" (25 mm)
Right	0" (0 mm)	3" (76 mm)
Back	2" (51 mm)	3" (76 mm)

Bakers Pride Oven Company, LLC is a wholly owned subsidiary of Standex International Corporation.

Bakers Pride reserves the right to modify specifications or discontinue models without incurring obligation. Dimensions nominal.



Freight Class: 77.5,  
FOB Allen 75013

