

Champion®

The Dishwashing Machine Specialists

Project _____
Item No. _____
Quantity _____

STANDARD FEATURES

- **ENERGY STAR® Qualified**
- *Exclusive DualRinse Technology*
- Dual-pawl cradle drive system
- One-piece cast stainless steel upper & lower spray arm assemblies
- Internal removable scrap basket with two-piece scrap screen
- Standard vertical opening accommodates 18" x 26" sheet pans
- Wide 15-1/2" and 26" leakproof doors, internally-fitted
- Anti-jam conveyor drive system
- Energy Sentinel (Idle pump shut-off)
- Convenient top-mounted controls
- Automatic tank fill
- Common utility connections
- Door safety switch
- Door activated drain closures
- Enclosure panels (front and sides)
- Splash shields
- Low-water tank heat protection
- Rinse-saver device
- Stainless steel heavy-gauge construction, including base and feet
- Electric tank heat
- Prewash pump 1 Hp motor
- External prewash scrap basket
- Wash pump 2 Hp motor
- Stainless steel pump and impellers
- Single-point electrical connection

*The DualRinse feature offers the **Lowest Water/Utility/Chemical Consumption** while circulating a generous 300+ gallons of water for **Consistently Good Results***

DualRinse™ MODEL 66 DRPW

44" Single Tank with 22" Prewash
High Temperature Rack Conveyor
Dishwashing Machine with
Dual Stage Rinse



Shown with Vent Cowl
and Damper Option

SPECIFIER STATEMENT

Specified unit will be Champion Model 66 DRPW high temperature dual rinse rack conveyor dishwashing machine. Constructed of Type 304 stainless steel and measuring 66" long with 20-3/4" vertical opening. Features top mounted control cabinet; upper and lower one-piece stainless steel spray arm assemblies, removable internal scrap basket with two-piece scrap screen, external prewash scrap basket. Large 15-1/2" prewash and 26" wash front access doors with double-hook safety latches. Anti-jam conveyor drive system. 1 year parts and labor warranty.

E-SERIES

DualRinse™



Champion Industries, Inc.
2674 N. Service Road,
Jordan Station, Ontario, Canada L0R 1S0
Tel: 800/263-5798 Fax: 905/562-4618

Champion Industries, Inc.
P. O. Box 4149, Winston-Salem, NC 27115
Tel: 800/532-8591 Fax: 336/661-1979
www.championindustries.com

Champion[®]

The Dishwashing Machine Specialists

MODEL 66 DRPW

44" Single Tank with 22" Prewash
High Temperature Rack Conveyor
Dishwashing Machine with
Dual Stage Rinse

EFFICIENT NEW SPRAY SYSTEM DESIGN

To make the E-Series more efficient and more forgiving we designed a new spray arm system that includes:

- Wall-of-water spray pattern via stainless steel fluted directional spray jets for quick and efficient washing
- Easily removable spray arm assembly for ease of cleaning
- Stainless steel pump housing and impeller
- Larger tanks hold more water for better washing results

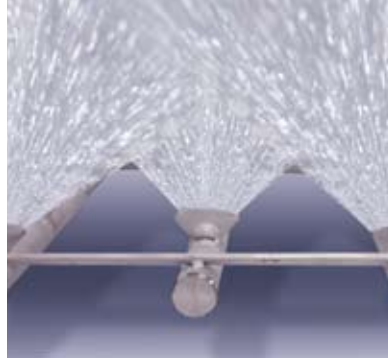

Wall-of-Water Spray Pattern



One-Piece Cast Stainless Steel Spray Assembly

INTEGRATED BOOSTER HEATER

As well as the E-Series performs, we created a way to make it perform even better. The electric booster heater may be optional, but it is an exceptional value — engineered within the E-Series footprint to offer a variety of advantages over other booster designs, such as:

- Inter-plumbed and inter-wired
- One control shuts off washer and booster
- 12 kW for 40°F rise
- 22 kW for 70°F rise
- Conductive heat transfer to wash tank
- Stainless steel booster heater lasts the life of the machine
- Integrated design saves floor space



Large Heating Element



Stainless Steel Built-in Nested Booster



Two-Piece Scrap Screen



Built-in Scrap Basket

LESS IS MORE WITH CHAMPION'S DUAL RINSE MODEL 66 DRPW

Check our NSF listings and you'll see the 44 DR offers the lowest water consumption in its class with less than .54 US gallons per rack. Water consumption this low means energy savings too. Our 40°F rise booster only requires 12 kW and 70°F rise is only 22 kW.

What the numbers don't show you is the advantage that our Dual Rinse technology provides by making sure all wares are fully rinsed with more than 300 gallons per hour while actual fresh water consumption is only 112 gallons per hour.

MODEL 66 DRPW

44" Single Tank with 22" Prewash
High Temperature Rack Conveyor
Dishwashing Machine with
Dual Stage Rinse

Champion[®]
The Dishwashing Machine Specialists

OPTIONS & ACCESSORIES

- Tank heat: choice of steam coil, steam injector, hot water coil
- Blower-dryer with 60" hood, table, legs and pawl bar assembly
- Booster Heaters
(completely interplumbed, controls are interwired)
 - Steam: 40°F - 70°F rise
 - Electric: 12 kW (40°F rise) (built-in only)
 - Electric: 22 kW (70°F rise) (built-in only)
- Cantilever sideloader (with or without hood) for 90° load operation
- Extended pawl bar (extended drive unit) for use with load tabling
- 90° Motorized rack curve (unload)
- 180° Motorized rack curve (unload)
- Racks: peg or flat racks (specify type)
- Roller conveyor table (mobile or stationary)
- Steam pressure regulating valve (unmounted)
- Table limit switch, unmounted (recommended on all rack conveyor installations)
- Vent cowl, stainless steel with 7" stack and locking damper
- Extended vent hood, stainless steel with 7" stack and locking damper
- Water pressure regulating valve (unmounted) (standard with booster)
- Vent fan control
- Two-point electrical connection
- Water hammer kit
- Drain temp kit
- Vertical clearance through machine: 24" (instead of standard 20") for larger ware

Model MRC 180

180° Motorized
Rack Curve
(Must be ordered with Roller
Conveyor Table)



Model MRC 90

90° Motorized
Rack Curve
(Must be ordered with
Roller Conveyor Table)



**Cantilever
Sideloader**
(No hood)

Model RCT 64 or RCT 84

Roller
Conveyor Table



MODEL 66 DRPW

44" Single Tank with 22" Prewash
 High Temperature Rack Conveyor
 Dishwashing Machine with
Dual Stage Rinse

Champion®

The Dishwashing Machine Specialists

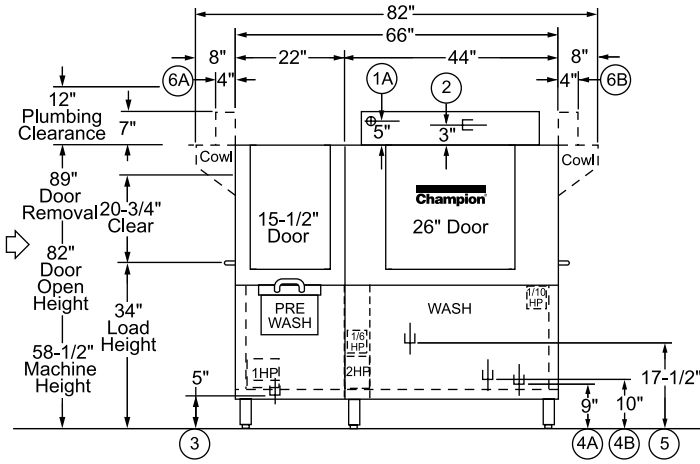

**Front View
 Without Booster**

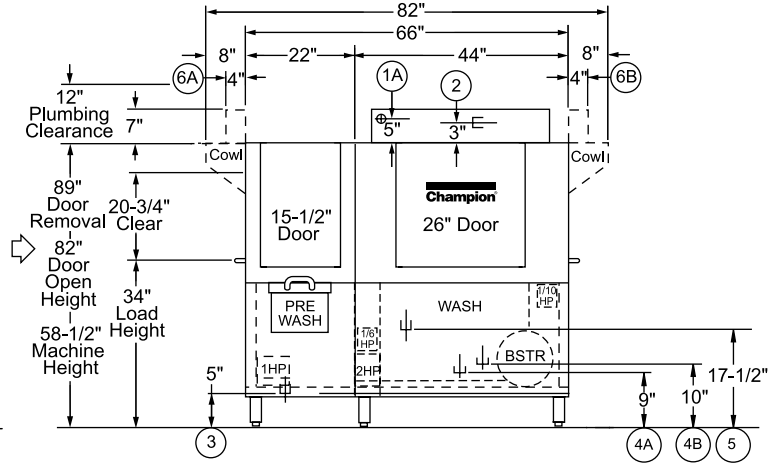

**Front View
 With Booster**

Left-to-Right Operation

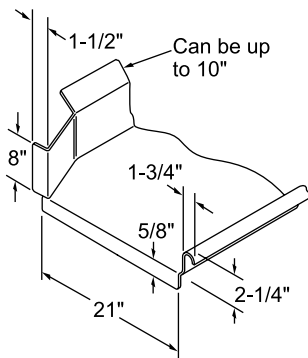

**Suggested Table
 Construction**

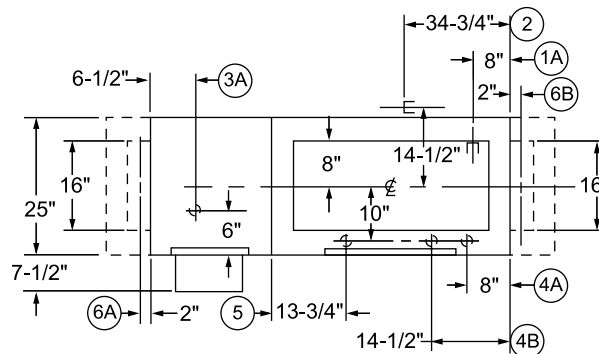

Plan View

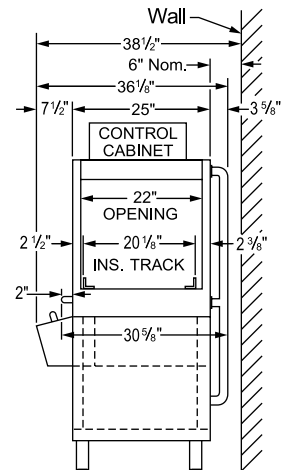

End View

MODEL 66 DRPW

44" Single Tank with 22" Prewash
High Temperature Rack Conveyor
Dishwashing Machine with
Dual Stage Rinse

Champion®

The Dishwashing Machine Specialists

Dimensions shown in inches

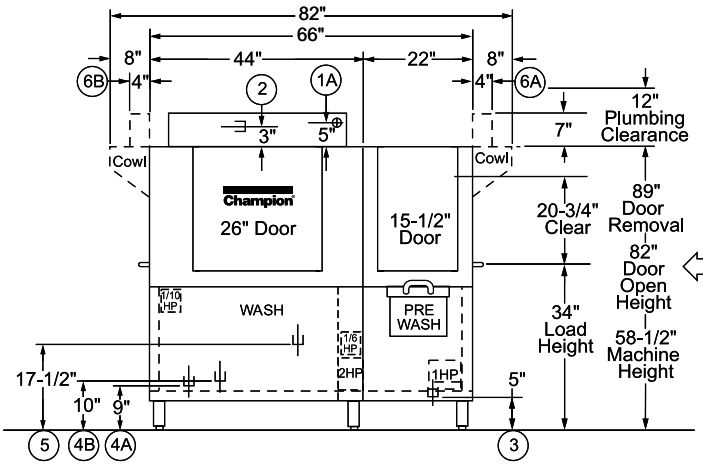

**Front View
Without Booster**

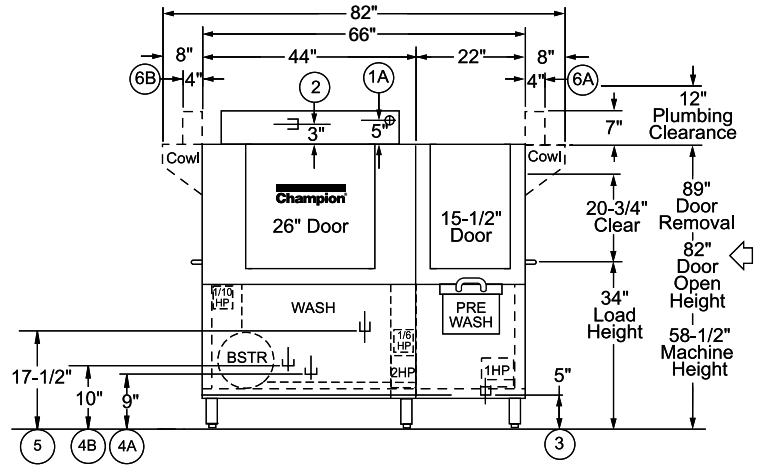

**Front View
With Booster**

Right-to-Left Operation

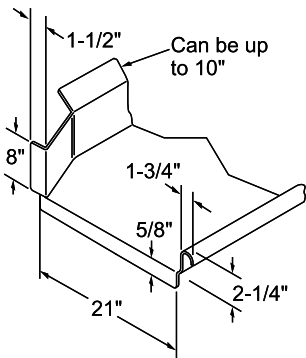

**Suggested Table
Construction**

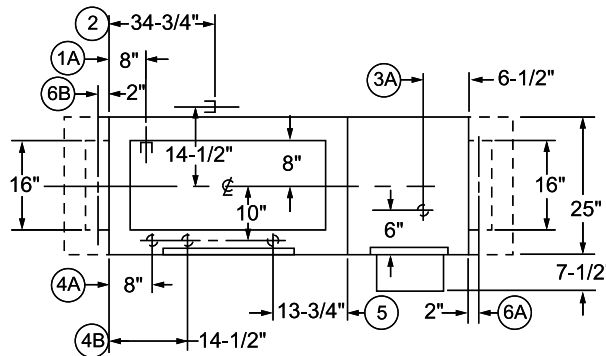

Plan View

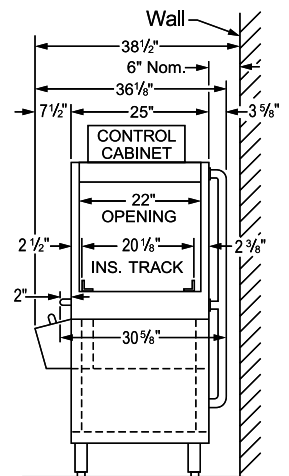

End View

MODEL 66 DRPW

44" Single Tank with 22" Prewash
High Temperature Rack Conveyor
Dishwashing Machine with
Dual Stage Rinse

Champion®

The Dishwashing Machine Specialists

Volume crated: **152 cu. ft.**
Shipping weight crated: **800 lbs.**

Utilities	
1 Electrical Connection	A Machine only (see Table A) B Machine & booster (see Table B)
2 Hot Water	3/4" NPT 180°F/82°C min. hot water connection. (Machine without booster.) 3/4" NPT 140°F/60°C min. hot water connection. (40°F/22°C rise booster) 3/4" NPT 110°F/49°C min. hot water connection. (70°F/39°C rise booster) Flow pressure 20-22 psi.
3 Drain	1-1/2" NPT machine connection. Maximum flow 15 gpm.
4 Steam	A 3/4" NPT machine connection. Flow pressure 15-30 PSI. (Steam coil) B 3/4" NPT machine connection. Flow pressure 15-30 PSI. (Steam injector)
5 Condensate (no back pressure)	1/2" NPT machine return to boiler
6 Vents	A Load end: 200 CFM @ 1/4" S.P. B Unload end: 400 CFM @ 1/4" S.P. (With blower-dryer increase room ventilation by 600 CFM.)

TABLE B - MACHINE & BOOSTER CONNECTION

40°F/22°C Rise – 12 kW Machine and Electric built-in booster			
Elec. Specs.	Rated Amps	Minimum Supply Ckt. Conductor Ampacity	Maximum Overcurrent Protective Device
208/60/1	178	225	225
240/60/1	155	200	200
208/60/3	108	150	150
240/60/3	94	125	125
480/60/3	47	60	60
575/60/3	37	50	50

70°F/39°C Rise – 22 kW Machine and Electric built-in booster			
Elec. Specs.	Rated Amps	Minimum Supply Ckt. Conductor Ampacity	Maximum Overcurrent Protective Device
208/60/1	226	300	300
240/60/1	197	250	250
208/60/3	136	175	175
240/60/3	118	150	150
480/60/3	60	80	80
575/60/3	47	60	60

TABLE A - MACHINE CONNECTION

Machine only			
Elec. Specs.	Rated Amps	Minimum Supply Ckt. Conductor Ampacity	Maximum Overcurrent Protective Device
208/60/1	120	150	150
240/60/1	105	150	150
208/60/3	74	100	100
240/60/3	65	90	90
480/60/3	33	45	45
575/60/3	25	35	35

Machine and steam built-in booster			
Elec. Specs.	Rated Amps	Minimum Supply Ckt. Conductor Ampacity	Maximum Overcurrent Protective Device
208/60/1	42	60	60
240/60/1	37	50	50
208/60/3	29	40	40
240/60/3	26	35	35
480/60/3	12	15	15

SPECIFICATIONS

Capacity

Racks per hr. (NSF rated)	208
Wash tank (US gal.)	21
Conveyor speed (ft/min.)	5.8

Motor Horsepower

Drive	1/6
Wash	2
Prewash	1
Dual Rinse	1/10

Water Consumption

US Gal. per hr. (max. use)	112
US Gal. per rack	.54

Heating

Wash Tank, electric (kW)	15
Dual Rinse Tank electric (kW)	3

Tank heat, steam (lbs/hr. required at 15 PSI flow pressure)	75
Electric booster (built-in) (kW supplied for 40°F rise)	12
Electric booster (kW supplied for 70°F rise)	22
Steam booster (lbs./hr. required for 40°F rise)	60
Steam booster (lbs./hr. required for 70°F rise)	106

Venting

Load end (minimum CFM)	200
Unload end (minimum CFM)	400

Standard 20" x 20" rack complement

Peg	2
-----	---

Warning: Plumbing and electrical connections should be made by qualified personnel who will observe all the applicable plumbing, sanitary, safety codes and the National Electrical Code.

Note: Water Hammer Arrestor (meeting ASSE-1010 standard or equivalent) to be supplied (by others) in common water supply line at service connection.

Plumbing Notes: Because of the variation in house-supplied steam and water pressures, steam and water pressure regulating valves (PRVs) may be needed. (Water PRV is standard on machines with booster.) The PRVs can either be purchased from Champion or obtained locally.

Venting Notes: Fabricated duct size: 3-7/8" x 15-7/8" (Outside dimensions)

Due to an ongoing value analysis program at Champion, specifications contained in this catalog are subject to change without notice.

Champion Industries, Inc., P. O. Box 4149, Winston-Salem, NC 27115 • 800/532-8591 • Fax: 336/661-1979 • www.championindustries.com
2674 N. Service Road, Jordan Station, Ontario, Canada L0R 1S0 • 800/263-5798 • Fax: 905/562-4618