

Champion®

The Dishwashing Machine Specialists

Project _____
 Item No. _____
 Quantity _____

UH-100B UNDERCOUNTER

STANDARD FEATURES

- Rinse Sentry – extends the cycle time to ensure 180°F final rinse.
- Built-in electric booster for 180°F final rinse water (standard 40°F or optional 70°F rise)
- Pumped drain
- Door safety switch
- Low-water tank heat protection
- Detergent and rinse aid pumps
- Quiet double-wall construction
- 15-3/4" door opening to accept larger wares, including trays
- Stainless steel top and side panels
- 140 second cycle
- Wash pump, 1 Hp motor
- Stainless steel construction
- Fill and dump
- Prime switch on control panel
- Automatic tank fill
- One year parts and labor warranty

UH-100B

Undercounter High Temperature Dishwashing Machine with Built-in Booster Heater



OPTIONS & ACCESSORIES

- 1-RDT Dish Table** Durable, heavy-gauge stainless steel dish table with sink, stand-pipe drain, removable scrap screen holder, drain-board, backsplash and lower storage cabinet. Sprayhose is optional. See 1-RDT catalog sheet) Specify right hand or left hand sink.
- Additional Dish Racks**
- 17" Rack Stand**
Stainless Steel
- 6" Leg Stand**
- 17" Storage Cabinet**
- 70° Rise Booster**

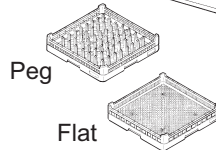
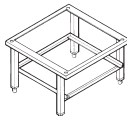

SPECIFIER STATEMENT

Specified unit will be Champion model UH-100B undercounter high temperature dishwashing machine with built-in booster heater.

Features 140 second total cycle, controls, Rinse Sentry, detergent and rinse aid pump, stainless steel top and side panels. Constructed of Type 304 stainless steel.

1 year parts and labor warranty.

Champion Industries, Inc.
 P. O. Box 4149, Winston-Salem, NC 27115
 Tel: 336/661-1556 Fax: 336/661-1979
www.championindustries.com

UH-100B

Undercounter High Temperature Dishwashing Machine with Built-in Booster Heater

Champion®

The Dishwashing Machine Specialists

Volume crated: **15 cu. ft.**
Shipping weight crated: **215 lbs.**

Dimensions shown in inches

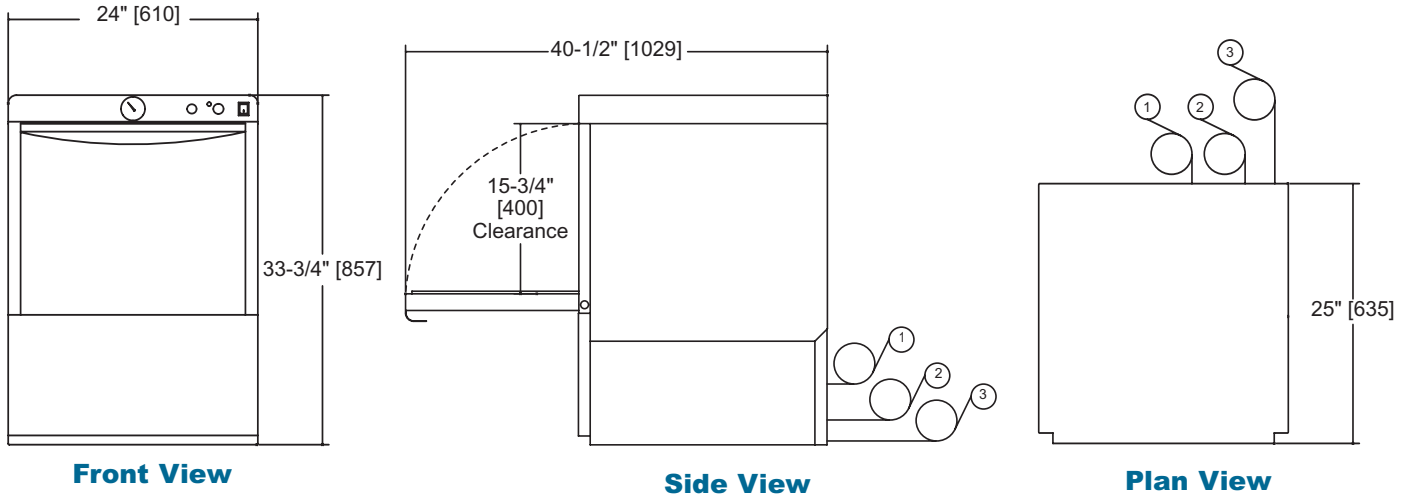

Utilities	
1 *Electrical	115/208-240/60/1; 3 wire + ground. Hard wiring required. (See boxes)
2 Water Connection	140°F/60°C Min., hot water connection for 40°F/22°C rise booster; 110°F/43°C Min., hot water connection for 70°F/39°C rise booster; 6 ft. long, 1/2" I.D. flexible fill hose with 3/4" hose connector. Flow pressure: 25-95 psi.
3 Pumped Drain	5/8" I.D. flexible reinforced hose, 6 ft. long. Max. drain flow 15 US gpm. Max. drain height 3 ft.

***Note:** Electrical supply service must be a 3-wire plus ground for connection.

Warning Plumbing and electrical connections should be made by qualified personnel who will observe all the applicable plumbing, sanitary and safety codes and the National Electrical Code.

UH-100B with 40°F/22°C Rise Booster

Elec. Specs.	Rated Amps	Minimum Supply Ckt. Conductor Ampacity	Maximum Overcurrent Protective Device
115/208/60/1	36	50	50
115/240/60/1	40	50	50

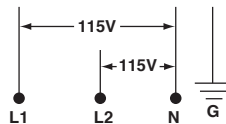

***Note:** Electrical supply service must be a 3-wire plus ground for connection as shown.

UH-100B with 70°F/39°C Rise Booster

Elec. Specs.	Rated Amps	Minimum Supply Ckt. Conductor Ampacity	Maximum Overcurrent Protective Device
115/208/60/1	48	60	60
115/240/60/1	51	70	70

SPECIFICATIONS

Capacity	Racks per hr. (NSF rated)	21
Motor horsepower	Wash	1
Water consumption	US Gal. per hr. (Max. use)	38
	US Gal. per rack	1.8
Temperatures °F/°C	Wash	150/66
	Rinse	180/82
Heating	Tank heat, electric (kW)	1.2
	Booster, elec., 40°F rise, kW	6
	Booster, elec., 70°F rise, kW	9
Time cycle in seconds	Wash	90
	Rinse	25
	Drain/fill	25
	Total cycle	140
Standard 20" x 20" rack complement	Dish	1
	Open	1