

Champion®

The Dishwashing Machine Specialists

Project _____
 Item No. _____
 Quantity _____

UH-100B UNDERCOUNTER

STANDARD FEATURES

- **NEW "Shear Energy"** – a reduction in energy requirements while maximizing performance!
- **NEW "Multi-Power"** – includes **"Multi-Volt"** and **"Multi-Phase"**. Allows for infield conversion to 208-240 volt and/or single to three phase with ease.
- **Rinse Sentry** – extends the cycle time to ensure 180°F final rinse.
- **Built-in electric booster** for 180°F final rinse water (standard 40°F or optional 70°F rise)
- Pumped drain
- Door safety switch
- Low-water tank heat protection
- Detergent and rinse aid pumps
- Quiet double-wall construction
- 15-3/4" door opening to accept larger wares, including trays
- Stainless steel top and side panels
- 141 second cycle
- Wash pump, 1 Hp motor
- Fill and dump
- Prime switch on control panel
- Automatic tank fill
- One year parts and labor warranty

UH-100B

Undercounter High Temperature Dishwashing Machine with Built-in Booster Heater

UH-100 Model without Booster Heater



NEW FEATURES

OPTIONS & ACCESSORIES

- 1-RDT Dish Table** Durable, heavy-gauge stainless steel dish table with sink, stand-pipe drain, removable scrap screen holder, drain-board, backplash and lower storage cabinet. Sprayhose is optional. See 1-RDT catalog sheet. Specify right hand or left hand sink.
- Additional Dish Racks**
- 17" Stand**
Stainless Steel
- 6" Leg Stand**
- 70°F Rise Booster**
- 3 Phase Connection (prewired at factory)**
- UH100 without Booster**
- 1" Roller Kit (includes 4 casters)**

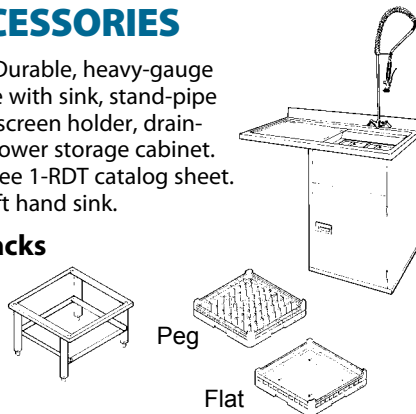

SPECIFIER STATEMENT

Specified unit will be Champion model UH-100B undercounter high temperature dishwashing machine with built-in booster heater.

Features 141 second total cycle, Rinse Sentry, detergent and rinse aid pump, stainless steel top and side panels. Constructed of stainless steel.

1 year parts and labor warranty.

Champion Industries, Inc.
 3765 Champion Blvd, Winston-Salem, NC 27105
 Tel: 336/661-1556 Fax: 336/661-1979
www.championindustries.com

UH-100B

Undercounter High Temperature Dishwashing Machine with Built-in Booster Heater

Champion®

The Dishwashing Machine Specialists

Volume crated: 15 cu. ft.
Shipping weight crated: 215 lbs.

Dimensions shown in inches and [millimeters]

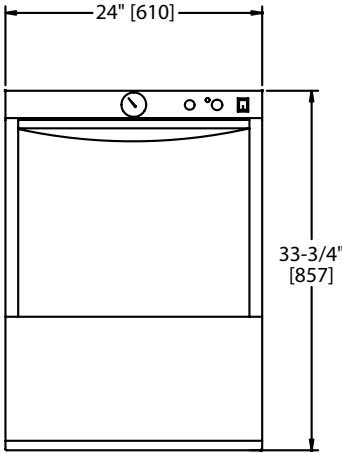

Front View

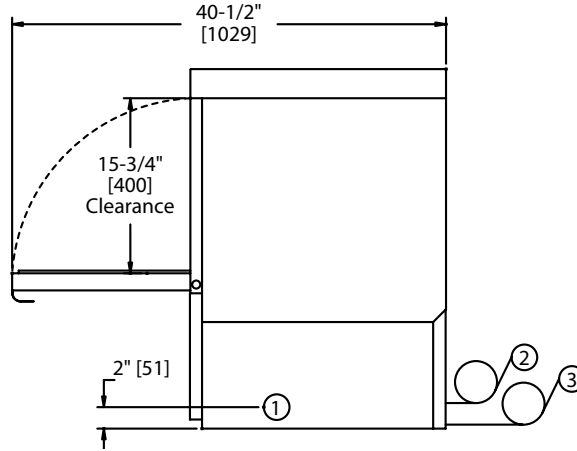

Side View

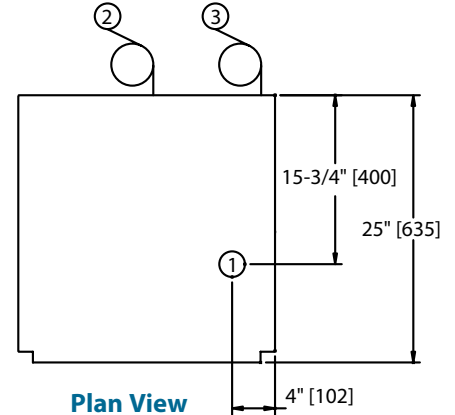

Plan View

Utilities

| | |
|----------|--|
| 1 | Electrical 208-240/60/1; 3 wire plus ground, (See Box). 208-240/60/3; 4 wire plus ground, (See Box). Field convertible to accept 3 phase power, see service manual for details |
| 2 | Hot Water 1/2" supply; 140°F/60°C Min. hot water connection for 40°F/22°C rise booster; 110°F/43°C Min. hot water connection for 70°F/39°C rise booster. Incoming supply pressure must maintain a Flow pressure 20-22 PSI (Pressure reducing valve, PRV, supplied by customer or may be purchased unmounted from Champion). Machine equipped with 3/4" [19] hose connector. |
| 3 | Pumped Drain 5/8" [15.9] I.D. flexible reinforced hose, 6 ft. [1829] long. Max. drain flow 15 US gpm. [12.5 imp gal] Max. drain height 3 ft. [914] |

Warning Plumbing and electrical connections should be made by qualified personnel who will observe all the applicable plumbing, sanitary and safety codes and the National Electrical Code.

UH-100B with 40°F/22°C Rise Booster

| Elec. Specs. | Rated Amps | Minimum Supply Ckt. Conductor Ampacity | Maximum Overcurrent Protective Device |
|--------------|------------|--|---------------------------------------|
| 208/60/1 | 32 | 40 | 40 |
| 240/60/1 | 36 | 40 | 40 |
| 208/60/3 | 22 | 30 | 30 |
| 240/60/3 | 24 | 30 | 30 |

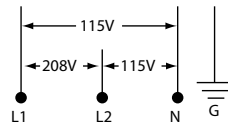

***Note:** Electrical supply service must be a 3-wire plus ground for connection as shown.

UH-100B with 70°F/39°C Rise Booster

| Elec. Specs. | Rated Amps | Minimum Supply Ckt. Conductor Ampacity | Maximum Overcurrent Protective Device |
|--------------|------------|--|---------------------------------------|
| 208/60/1 | 45 | 60 | 60 |
| 240/60/1 | 50 | 60 | 60 |
| 208/60/3 | 29 | 35 | 35 |
| 240/60/3 | 33 | 40 | 40 |

| UH-100 without booster 750 Watt tank heat | |
|--|------------|
| Elec. Specs. | Rated Amps |
| 115/60/1 | 12 |

SPECIFICATIONS

| | | |
|---|-------------------------------|--------|
| Capacity | Racks per hr. (NSF rated) | 21 |
| Motor horsepower | Wash | 1 |
| Water consumption | US Gal. per hr. (Max. use) | 38 |
| | US Gal. per rack | 1.8 |
| Temperatures °F/°C | Wash | 150/66 |
| | Rinse | 180/82 |
| Heating | Tank heat, electric (kW) | 2.0 |
| | Booster, elec., 40°F rise, kW | 6 |
| | Booster, elec., 70°F rise, kW | 9 |
| Time cycle in seconds | Wash | 90 |
| | Rinse | 26 |
| | Drain/fill | 25 |
| | Total cycle | 141 |
| Standard 20" x 20" rack complement | Dish | 1 |
| | Open | 1 |

Due to an ongoing value analysis program at Champion, specifications contained in this catalog are subject to change without notice.

Champion Industries, Inc., 3765 Champion Blvd, NC 27105 • 336/661-1556 • Fax: 336/661-1979 • www.championindustries.com