



COUNTERTOP ROTISSERIE – DOUBLE ROTATION – PASS-THROUGH

# Model DR-34



One our most popular rotisseries, the BKI® DR-34 countertop rotisserie really attracts attention with its double-revolving rotor system. While individual skewers rotate, the entire cooking mechanism also revolves, resulting in even cooking and self-basting glory. Anything you cook in the DR-34 will be enhanced by the drippings of the product above, creating mouth-watering food that will keep customers coming back for more.

This rotisserie is a pass-through unit, allowing the back of the kitchen to load raw product and the front kitchen to pull cooked product, thus reducing the risk of contamination.

The built-in automatic "hot hold" feature cooks food to perfection, then automatically moves to holding temperature to keep food looking and tasting great for hours.

Manual controls are easy to use so no matter who uses the rotisserie, the results will be consistently delicious.

Cleaning the rotisserie is easy thanks to the removable rotating assembly and fat collection tray.

Whether poultry, pork, beef, or your own specialty, the DR-34 rotisserie is sure to maximize counter space and produce consistent results every time.

## FEATURES AT A GLANCE

- Double-revolving rotor system for even cooking and self-basting
- Removable drive system and fat collection pan
- Programmable single stage cook computer
- Tubular heating elements
- Lamps for product illumination
- Fan for cooling electrical components
- Pass-through design
- Built-in automatic "hot hold"
- 100% hand built in the U.S.A.



### PRODUCT CAPACITY

Cooks up to 20 3-lb (1.36 kg) chickens in 75 minutes at the touch of a button.



### ELECTRIC OPERATION

Energy efficiency and easy installation are a perfect pairing for your food service operation.

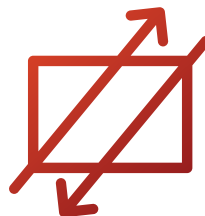

### PASS-THROUGH DESIGN

Pass-through models allow for rear loading of raw product which reduces contamination risks.



COUNTERTOP ROTISSERIE – DOUBLE ROTATION – PASS-THROUGH

# Model DR-34

## EQUIPMENT DIMENSIONS

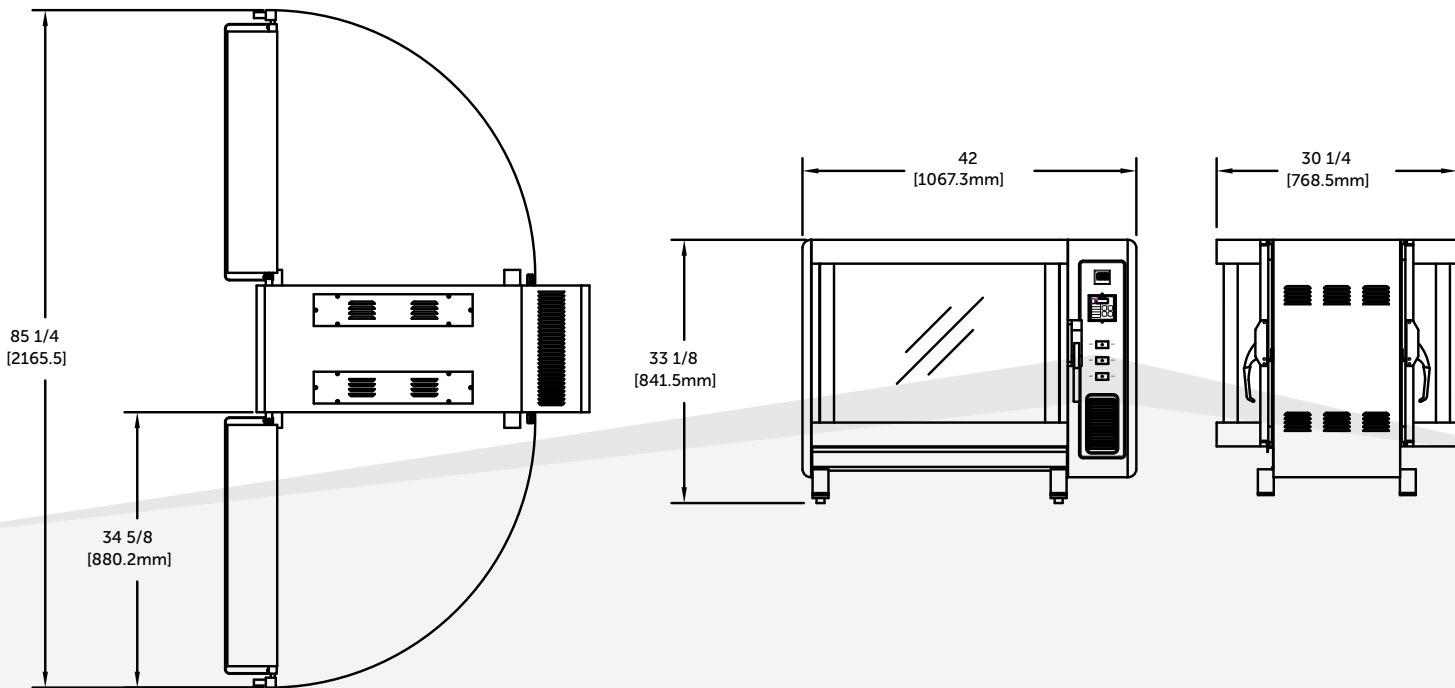

## MECHANICAL SPECIFICATIONS

Dimension	Uncrated
Height	33.12" (842 mm)
Width	42" (1067 mm)
Depth	30.25" (769 mm)
Floor Space	8.8 sq ft (.82 sq m)
Weight	390 lb (176.9 kg)

## ELECTRICAL OPTIONS

Volts	Amps	Breaker	kW	Wires	Phase
208	17.43	25	6.18	3	3
208	29.7	40	6.18	2	1
220	18.41	25	6.91	3	3
220	31.4	40	6.91	2	1
240	15.21	20	6.21	3	3
240	25.9	35	6.21	2	1
220/380	12	15	6.9	4	3
220/380	31.5	35	6.2	2	1
240/415	10	15	6.2	4	3
240/415	25.9	35	6.2	2	1

## OPTIONS

- Purchase price includes one set of either "V" spits, meat forks or meat baskets



Visit [bkideas.com](http://bkideas.com) to view all accessories available for this model.

6.15.2017