



Fresh ideas in foodservice equipment

Hot-N Crispy™ FRY WARMER

Model: UW-17

*Innovative Fry Warmer
extends hold life of fried food
by using convection heat
technology.*



Keep fried foods hot, moist and delicious while maintaining a crispy exterior. Extend hold time without drying or creating a tough texture or a limp product.

Double or triple* hold times of:

- Fries
- Chicken Tenders
- Nuggets
- Appetizers and more

* Hold times vary by product and corporate specifications

Agency Approvals:



Features & Benefits:

- Overheat safety system
- Pan Divider
- Safety Cut-Off
- Removable parts for easy cleaning

BKI North America
PO Box 80400
Simpsonville, SC 29680-0400 USA
Telephone: (864) 963-3471
Toll Free: (800) 927-6887

BKI Europe
Theale Technology Centre
Station Road • Theale
Reading • West Berkshire • RG7 4AA
Telephone: 0870 9904242 • Fax: 0870 9904243



UW-17

Equipment Dimensions:

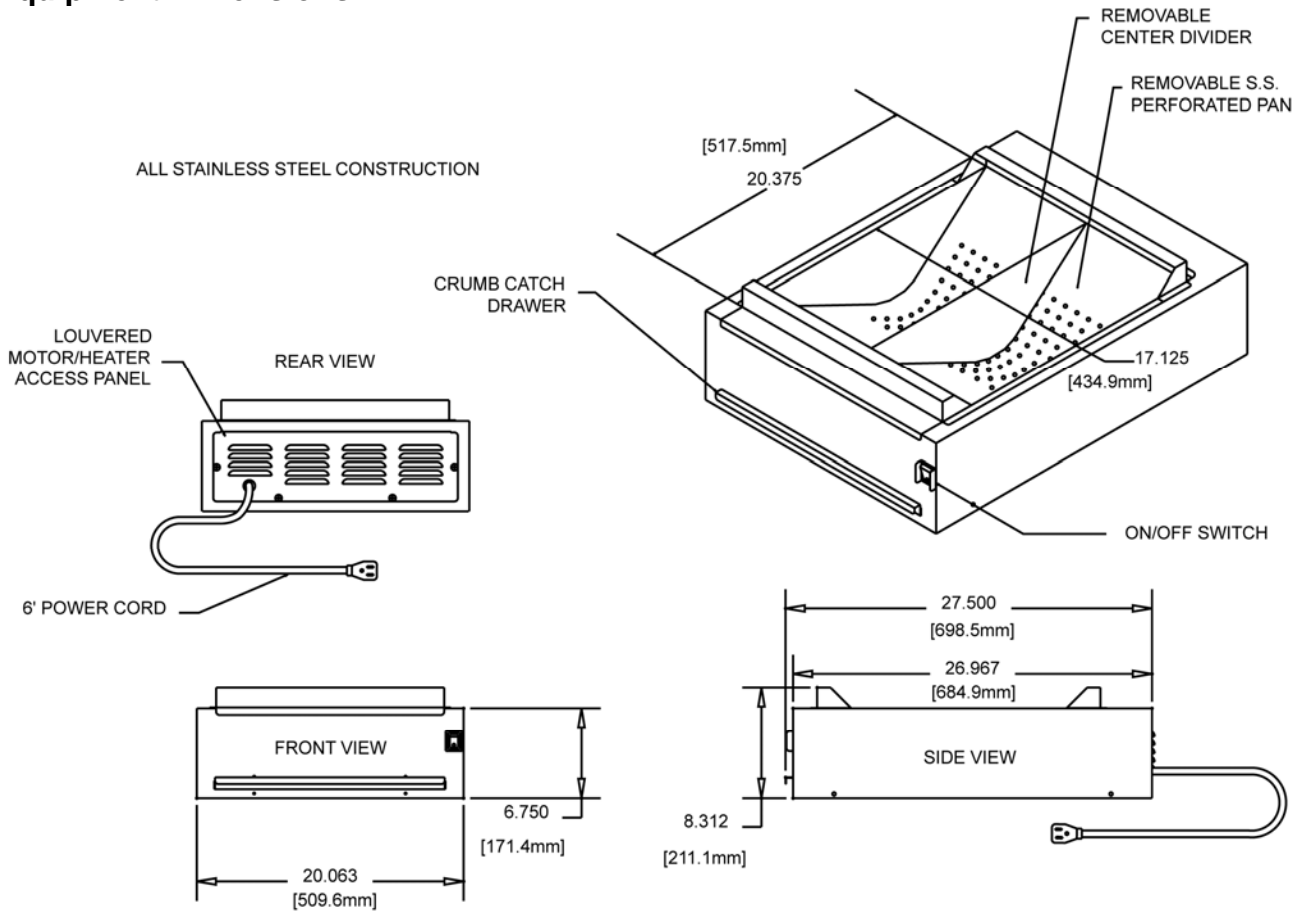

Mechanical Specifications:

Dimension	Uncrated	Crated
Height	8.3 in (211mm)	9 in (228mm)
Width	20 in (509.6mm)	21 in (533mm)
Depth	27.5 in (698.5mm)	28.5 in (724mm)
Floor Space	3.82 sq ft (0.355m ²)	3.12 ft ³ (.088 M ³)
Weight	70 lb. (31.75 kg.)	75 lb. (34.02 kg.)

Electrical Specifications:

Volts	Amps	Breaker	KW	Wires	Phase
120	8.3	15	1	2	1

BKI North America
 PO Box 80400
 Simpsonville, SC 29680-0400 USA
 Telephone: (864) 963-3471
 Toll Free: (800) 927-6887

BKI Europe
 Theale Technology Centre
 Station Road • Theale
 Reading • West Berkshire • RG7 4AA
 Telephone: 0870 9904242 • Fax: 0870 9904243

