



*Fresh ideas in foodservice equipment*



Unit shown as two well self-serve with four well full-serve, curved front glass, on a standard base

#### Configuration Highlights:

- 3, 4, 5, 6, and 7 well units available in full-serve, self-serve, or any combination within two or more well increments
- All units are available as countertop models or floor standing, with a variety of optional base heights
- Available options of drop-in pan, flat surface, or combination display case configuration
- Floor standing units include available options of a stainless steel or painted finish base, pedestal base, and protective bumper
- Choice of curved or straight front glass
- Option of glass or solid end panels
- Units can be connected, providing a "continuous run" look, by using available joining kit accessory

# Global Series Heated Display Merchandiser

## WDCG-6, Six Well System

The BKI Global Series of heated display merchandisers are designed and engineered to provide operators maximum profitability in their hot food program by offering great flexibility and optimum holding capability.

Global Series units are available in a wide range of display configurations including all full-serve, all self-serve, and an expanded variety of combination units as well. Further versatility of curved or straight front glass, drop in pans or flat surface display, and glass or solid end panels, allows the operator to customize their hot food program to fit their specific concept.

All Global Series merchandisers offer reliable and precise holding temperatures by providing upper and lower heat control for each well, from one centralized "TouchTEC" control.

#### Standard Features:

- One centralized control positioned on service side canopy for easy operator access and monitoring
- Centralized TouchTEC control sets both upper and lower independent heaters for each individual well, enabling the operator to hold a wide variety of foods at their optimum temperature
- TouchTEC control provides precise and consistent temperature settings with built in program lock capability
- Recessed, shatter resistant, fluorescent lighting is not used as a heating source, providing maximum visibility and effective merchandising of displayed food items at all times
- Rear service doors are available in mirrored or clear glass and can be removed for easy case cleanup
- Front glass lifts up and locks for cleaning access from the front side
- Fold down and removable cutting board is available in plastic or stainless steel for service side ease of operation
- All units are shipped with fluorescent lights and divider bars (for drop-in pan display units), or surface warmer racks (for flat surface display units)

#### Available Accessories

- Digital read out food probe and receptacle
- Countertop adjustable legs
- Joining strip kit
- Stainless steel cutting board with drop-in pan cut outs
- Sliding base doors for floor standing units
- Scale stand

**BKI North America**  
PO Box 80400  
Simpsonville, SC 29680-0400 USA  
Telephone: (864) 963-3471  
Toll Free: (800) 927-6887

**BKI Europe**  
Theale Technology Centre  
Station Road • Theale  
Reading • West Berkshire • RG7 4AA  
Telephone: 0870 9904242 • Fax: 0870 9904243

 **Standex**  
Food Service Equipment Group

# WDCG-6

## Dimensions: inches [millimeters]

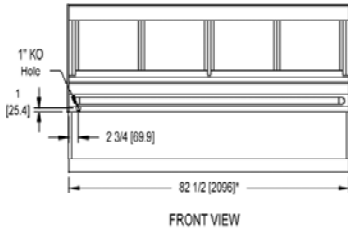
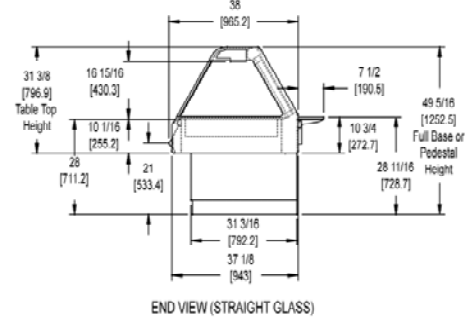
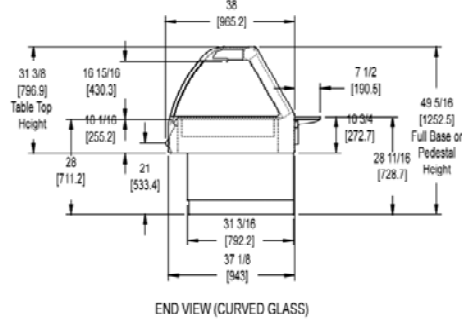
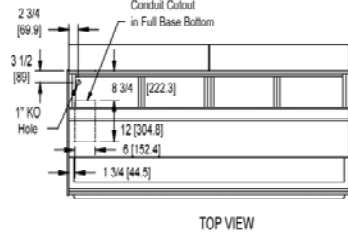

\* Add 1/2 [12.7] for each Glass End  
Add 3/4 [19.1] for each Solid End

## Configurations:

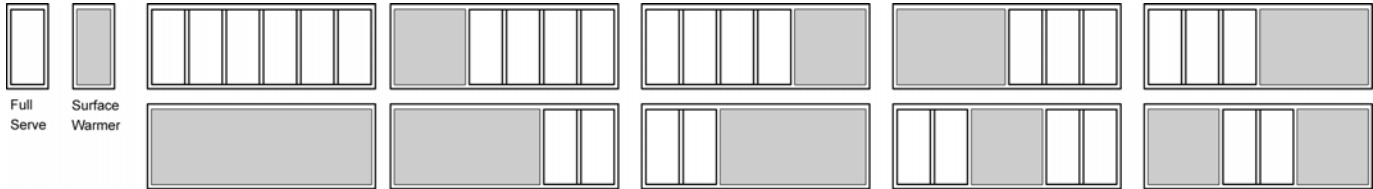

**Full-Serve Pan Capacity:** Each full-serve well holds one full-size pan and one third-size pan up to 4in. (102 mm) depth.

**Self-Serve Area:**  
 6-well section: 26 3/4 x 79 1/4 in. (679 x 2013 mm)  
 4-well section: 26 3/4 x 52 1/4 in. (679 x 1327 mm)  
 3-well section: 26 3/4 x 38 3/4 in. (679 x 984 mm)  
 2-well section: 26 3/4 x 25 1/4 in. (679 x 641 mm)  
 Insert depth 1 (25 mm)

## Electrical Options:

Volts	208	220	240	230/400	240/415
Phase	3/1	3/1	3/1	3/1	3/1
Amps	23.5/39.5	19.0/32.3	20.6/35.1	11.7/33.4	12.2/34.8
kW	8.2	7.1	8.4	7.7	8.4
Breaker	30/50	25/45	30/45	15/45	20/45
Wires	3/2	3/2	3/2	4/2	4/2

## Mechanical Specifications:

Floor Space	Shipping Cube	Shipping Wt. (Table Top)	Shipping Wt. (Floor or Pedestal)
21.8 sq. ft. (2.0 sq. m)	155 cubic ft. (4.4 cubic m)	675 lb. (306 kg)	820 lb. (372 kg)

Agency Approvals:



**BKI North America**  
 PO Box 80400  
 Simpsonville, SC 29680-0400 USA  
 Telephone: (864) 963-3471  
 Toll Free: (800) 927-6887

**BKI Europe**  
 Theale Technology Centre  
 Station Road • Theale  
 Reading • West Berkshire • RG7 4AA  
 Telephone: 0870 9904242 • Fax: 0870 9904243

