

CFS11, CFS01, CFS12 & CFS02

Application

- Multipurpose

Water Filtration Housings

Spec No. _____

Quantity _____



Product Features

- ◆ Various style head configurations, such as built-in pressure relief button and built-in shut-off valve, offer maximum flexibility.
- ◆ 3/4" NPT connections with 1/2" adapters provide multiple sizes for either point-of-entry or single applications with higher flow rates.
- ◆ Pressure tested high impact plastic designs available with either opaque or transparent housing configurations offer reliable product durability.

CUNO's line of drop-in filter housings accommodate our line of premium performance sediment and chlorine taste and odor reduction cartridges. Housings with filters can be used as in-line protection for point-of-entry, or equipment protection at point-of-use. Optional variants such as pressure gauges, built-in valve-in-head, and opaque or transparent housings are suitable for use with most applications and budgets.

Product Specifications - Housings for 9 3/4" Cartridges

Model Number	Part Number	Description	Cartridge Replacement
CFS11	55588-01	Opaque, Non-Valved Head, 1/2" Connections	CFS8504-A, CFS117, CFS117-S, CFS110, CFS111, CFS124, CFSMZ9.75
CFS11T	55588-02	Transparent, Non-Valved Head, 1/2" Connections	
CFS01LG	55575-03	Opaque, Valve-In-Head, 1/2" Connections	
CFS01TLG	55575-06	Transparent, Valve-In-Head, 1/2" Connections	
CFS01	55575-01	Opaque, Valve-In-Head, 1/2" Connections, Pressure Gauge	
CFS01T	55575-05	Transparent, Valve-In-Head, 1/2" Connections, Pressure Gauge	

Product Specifications - Housings for 19 1/2" Cartridges

Model Number	Part Number	Description	Cartridge Replacement
CFS12	55589-01	Opaque, Non-Valved Head, 1/2" Connections	CFS8504-B, CFS117*, CFS117-S*, CFS110*, CFS111*, CFS124*, CFSMZ19.5, CFSFR-5, CFSFR-10
CFS12T	55589-02	Transparent, Non-Valved Head, 1/2" Connections	
CFS02LG	55576-09	Opaque, Valve-In-Head, 1/2" Connections	
CFS02TLG	55576-06	Transparent, Valve-In-Head, 1/2" Connections	
CFS02	55576-01	Opaque, Valve-In-Head, 1/2" Connections, Pressure Gauge	

* Requires two cartridges



Visit www.nsf.org for the claims associated with products that are NSF listed.



Water Filter Systems

Foodservice

CFS11, CFS01, CFS12 & CFS02 Water Filtration Housings

Spec No. _____
 Quantity _____
 Model Number _____
 Part Number _____

Installation Tips:

- Shut off downstream equipment prior to installation of the system.
- Do not exceed operating parameters for temperature or pressure.
- For cold water use only.
- For commercial use only.

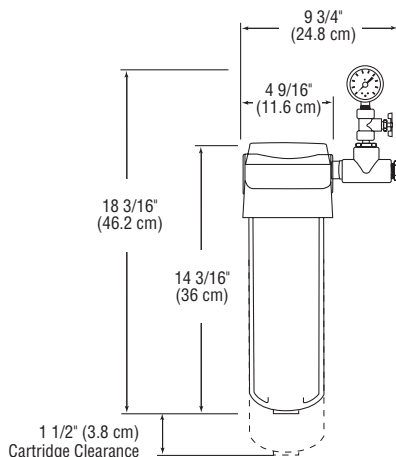

CFS01

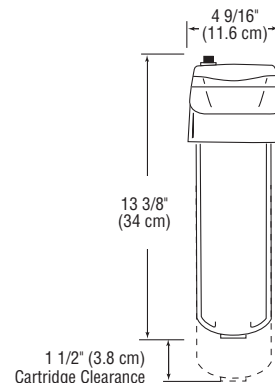

CFS11

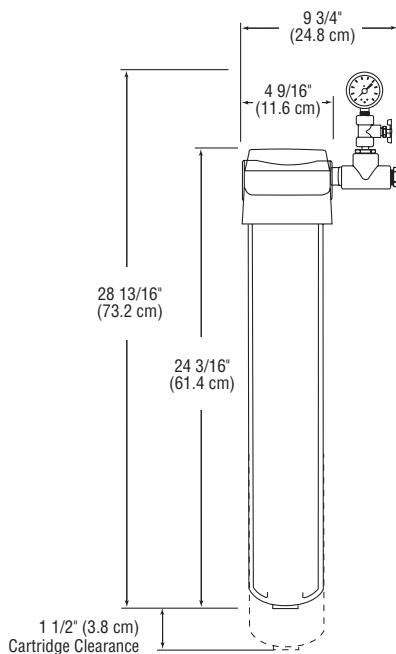

CFS02

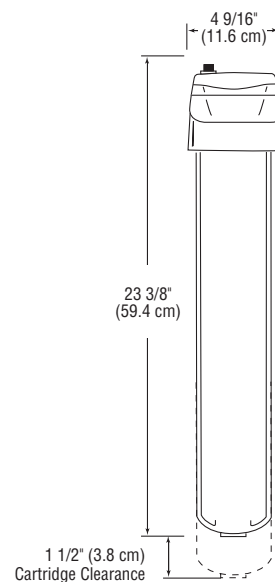

CFS12

Do not use with water that is microbiologically unsafe or of unknown quality without adequate disinfection before or after the system.

CUNO Incorporated recommends regularly scheduled maintenance and replacement of the filter cartridge(s) in order for the product to perform as advertised/sold.

Limited 5 Year Warranty

CUNO Incorporated warrants to the original purchaser-consumer that this product is free from defects in materials and workmanship. This warranty, together with any and all warranties implied by law, shall be limited to a period of five (5) years from the date of original purchase by the consumer. This warranty does not apply to failures that result from abuse, misuse, alteration or damage not caused by CUNO. This warranty is subject to exclusions and limitations. Please refer to the Warranty Card provided with the product for details.

Service Worldwide

China
 CUNO Filtration Shanghai Co. Ltd.
 No. 2 Plant East Side
 Xin Miao San Road
 XinQiao Town SongJiang District
 Shanghai, China 201612

Australia
 CUNO Pacific Pty Ltd.
 140 Sunnholt Road
 Blacktown, N.S.W. 2148
 Australia

Europe
 CUNO Limited
 21 Woking Business Park
 Albert Drive
 Woking, Surrey
 GU21 5JY, England



Japan
 CUNO K.K.
 Hodogaya Station Building 6F
 1-7, Iwai-Cho, Hodogaya-Ku
 Yokohama 240-0023, Japan

Brazil
 CUNO Latina Ltda
 Rua AMF do Brazil - 251
 18120 Mairinque-SP, Brazil

Singapore
 CUNO Filtration Asia Pte Ltd
 18 Tuas Link 1
 3rd Floor
 Singapore 638599

CUNO Incorporated
 400 Research Parkway
 Meriden, CT 06450, USA
 Toll Free: 1-888-218-CUNO
 Worldwide: 203-237-5541
 Fax: 203-238-8701