



# THE Waterless Steamer (WS)



Project \_\_\_\_\_

Item No. \_\_\_\_\_

Quantity \_\_\_\_\_

WS™

### PERFORMANCE

Utilizing TurboChef's patented technology to rapidly cook food without compromising quality, the WS oven utilizes the i-Series technology packaged in marine-grade stainless, able to withstand high-steam and saline environments. Perfectly steam vegetables, meats, seafood, and more while saving over 300,000 gallons of water per year.

### VENTILATION

- UL® (KNLZ) listed for ventless operation.<sup>†</sup>
- EPA 202 test (8 hr):
  - Product: Pepperoni Pizzas
  - Results: 0.64 mg/m<sup>3</sup>
  - Ventless Requirement: <5.00 mg/m<sup>3</sup>
- Internal catalytic filtration to limit smoke, grease, and odor emissions.

### EXTERIOR CONSTRUCTION

- Corrosion-resistant (316 stainless steel) outer wrap and door
- Chrome top panel
- Cool-to-touch exterior; all surfaces below 50°C
- 4-inch adjustable legs

### INTERIOR CONSTRUCTION

- Corrosion-resistant (316 stainless steel) cavity and blower wheels
- Fully welded and insulated cook chamber
- Removable rack and lower jetplate

### STANDARD FEATURES

- Independently-controlled dual motors for vertically-recirculated air impingement
- Top-launched microwave system
- Stirrer to help ensure even distribution of air and microwave
- Integral recirculating catalytic converter for UL® (KNLZ) listed ventless operation
- External air filtration
- Vent catalyst to further limit emissions and odors
- Cartridge style cavity filter to trap grease
- Lower panel collects light moisture and runoff
- LED timer counts down last 30 seconds of cook time
- Smart menu system capable of storing up to 256 recipes
- Flash firmware updates via smart card
- Single or dual-temperature interface
- Field-configurable for single or multiphase operation (requires service call)
- Self-diagnostics for monitoring oven components and performance
- Smart Voltage Sensor Technology\* (U.S. only)
- Includes plug and cord (6 ft. nominal)
- Warranty – 1 year parts and labor

### COMES WITH STANDARD ACCESSORIES

- 1 Bottle Oven Cleaner (103180)
- 1 Bottle Oven Guard (103181)
- 2 Trigger Sprayers (103182)
- 2 Solid Aluminum Pans (i1-9496)
- 1 Aluminum Paddle (i1-9716)

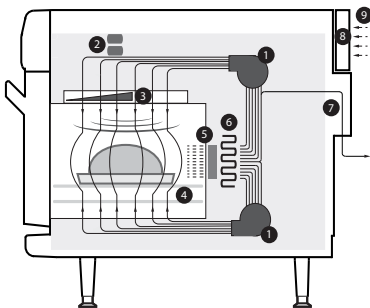

1. Blower Motors
2. Microwave System
3. Stirred Impinged Air (Top) and Microwave
4. Impinged Air (Bottom)
5. Catalytic Converter
6. Impingement Heater
7. Vent Tube Catalyst
8. Air Filter
9. Inlet Air for Cooling Electronic Components



This product conforms to the ventilation recommendations set forth by NFPA96 using EPA202 test method.

\* Smart Voltage Sensor Technology does not compensate for lack of or over voltage situations. It is the responsibility of the owner to supply voltage to the unit according to the specifications on the back of this sheet.

<sup>†</sup> Ventless certification is for all food items except for foods classified as "fatty raw proteins." Such foods include bone-in, skin-on chicken, raw hamburger meat, raw bacon, raw sausage, steaks, etc. If cooking these types of foods, consult local HVAC codes and authorities to ensure compliance with ventilation requirements.

Ultimate ventless allowance is dependent upon AHJ approval, as some jurisdictions may not recognize the UL certification or application. If you have questions regarding ventless certifications or local codes, please email ventless.help@turbochef.com

TurboChef reserves the right to make substitutions of components or change specifications without prior notice.



WS™

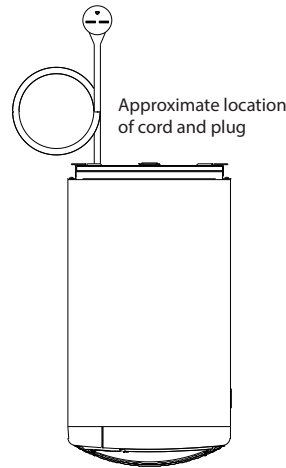
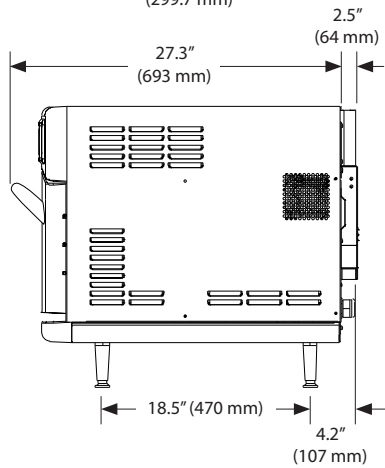
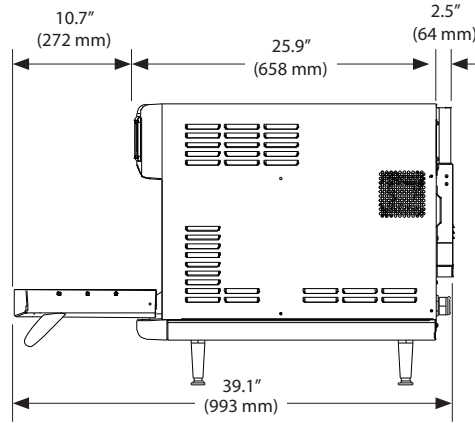
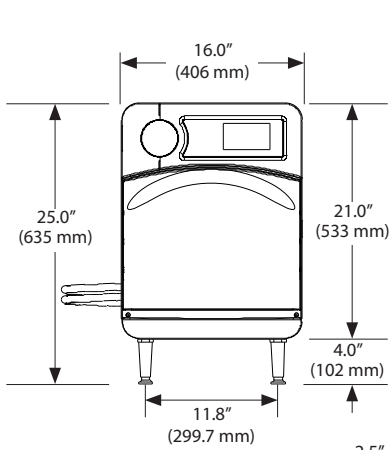

- US, CAN, LA (NEMA 6-30P)
- UK, BK (IEC 309, 3-pin)
- JK (NEMA L6-50, PSE, 3-blade)
- JD (NEMA L6-50, PSE, 4-blade)
- ED, BD, SD (IEC 309, 4-pin)
- EW, KW (IEC 309, 5-pin)
- AU (Clipsal, 5-pin)

DIMENSIONS		
Single Units		
Height	25.0"	635 mm
Width	16.0"	406 mm
Depth	29.8"	757 mm
Weight	170 lb.	77.1 kg
Cook Chamber		
Height	7.2"	183 mm
Width	12.5"	317 mm
Depth	10.5"	266 mm
Volume	0.54 cu.ft.	15.4 liters
Wall Clearance (Oven not intended for built-in installation)		
Top	5"	102 mm
Sides	1"	25 mm
SHIPPING INFORMATION		
U.S.: All ovens shipped within the U.S. are packaged in a double-wall corrugated box banded to a wooden skid.		
International: All International ovens shipped via Air or Less than Container Loads are packaged in wooden crates.		
Box size: 37" x 24" x 37" (940 mm x 610 mm x 940 mm)		
Crate size: 38" x 26" x 38" (965 mm x 660 mm x 965 mm)		
Item class: 110 NMFC #26710 HS code 8419.81		
Approximate boxed weight: 205 lb. (93 kg)		
Approximate crated weight: 275 lb. (125 kg)		
Minimum entry clearance required for box: 24.5" (622 mm)		
Minimum entry clearance required for crate: 26.5" (673 mm)		

ELECTRICAL SPECIFICATIONS		
SINGLE PHASE		
US/Canada	I1-9500-91-US	208/240 VAC, 60 Hz, 30 amps Max Input: 6.2 kW / MW: 3.2 kW / HTR: 6.0 kW
Europe (UK)	I1-9500-92-UK	230 VAC, 50 Hz, 27 amps Max Input: 6.2 kW / MW: 3.2 kW / HTR: 6.0 kW
Brazil (BK)	I1-9500-96-BK	220 VAC, 60 Hz, 28 amps Max Input: 6.2 kW / MW: 3.2 kW / HTR: 6.0 kW
Latin America (LA)	I1-9500-97-LA	220 VAC, 60 Hz, 28 amps Max Input: 6.2 kW / MW: 3.2 kW / HTR: 6.0 kW
Japan (JK)	I1-9500-98-JK	200 VAC, 50 Hz, 30 amps Max Input: 6.2 kW / MW: 3.2 kW / HTR: 6.0 kW
Japan (JK)	I1-9500-100-JK	200 VAC, 60 Hz, 30 amps Max Input: 6.2 kW / MW: 3.2 kW / HTR: 6.0 kW
MULTIPHASE		
Europe Delta (ED)	I1-9500-93-ED	230 VAC, 50 Hz, 20 amps Max Input: 6.2 kW / MW: 3.2 kW / HTR: 6.0 kW
Europe Wye (EW)	I1-9500-94-EW	400 VAC, 50 Hz, 16 amps Max Input: 6.2 kW / MW: 3.2 kW / HTR: 6.0 kW
Australia Wye (AU)	I1-9500-95-AU	400 VAC, 50 Hz, 16 amps Max Input: 6.2 kW / MW: 3.2 kW / HTR: 6.0 kW
Japan Delta (JD)	I1-9500-99-JD	200 VAC, 50 Hz, 20 amps Max Input: 6.2 kW / MW: 3.2 kW / HTR: 6.0 kW
Japan Delta (JD)	I1-9500-101-JD	200 VAC, 60 Hz, 20 amps Max Input: 6.2 kW / MW: 3.2 kW / HTR: 6.0 kW
Korea/Middle East Wye (KW)	I1-9500-102-KW	400 VAC, 60 Hz, 16 amps Max Input: 6.2 kW / MW: 3.2 kW / HTR: 6.0 kW
Korea/Middle East Delta (SD)	I1-9500-103-SD	230 VAC, 60 Hz, 20 amps Max Input: 6.2 kW / MW: 3.2 kW / HTR: 6.0 kW

**TurboChef Global Operations**

2801 Trade Center Drive | Carrollton, Texas 75007 USA  
 US: 800.90TURBO (800.908.8726) | International: +1 214.379.6000  
 Fax: +1 214.379.6073 | www.turbochef.com

**⚠ TurboChef recommends installing a type D circuit breaker for European installations.**