



TRUE MANUFACTURING CO., INC.
U.S.A. FOODSERVICE DIVISION

2001 East Terra Lane • O'Fallon, Missouri 63366-4434 • (636)240-2400
 Fax (636)272-2408 • Toll Free (800)325-6152 • Intl Fax# (001)636-272-7546
 Parts Dept. (800)424-TRUE • Parts Dept. Fax# (636)272-9471 • www.truemfg.com

Project Name: _____

Location: _____

Item #: _____ Qty: _____

Model #: _____

A/A #

S/S #

Model:
TAC-30-LD

Vertical Air Curtains:
Refrigerator with LED Lighting

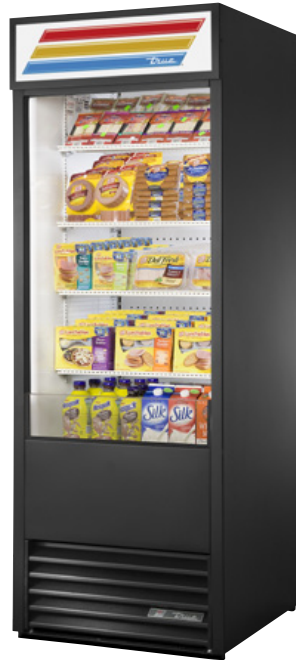

TAC-30-LD

- ▶ True's air curtain merchandisers are designed with enduring quality that protects your long term investment.
- ▶ Designed using the highest quality materials and components to provide the user with colder product temperatures and lower utility costs in an attractive merchandiser that brilliantly displays food and beverages.
- ▶ Large, open front allows easy access to display levels and places maximum attention on merchandising.
- ▶ Oversized, factory balanced, refrigeration system holds 35°F to 40°F (1.6°C to 4.4°C).
- ▶ Patented reversing condenser fan motors. Fan motors reverse during defrost off cycles to help keep condenser coil free from dirt, dust and debris. Keeping coils clean optimizes the unit's performance providing colder holding temperatures and increased energy efficiency. Regularly scheduled thorough cleaning of coils still recommended.
- ▶ Durable and permanent non-peel or chip white vinyl exterior with white aluminum interior and stainless steel floor and deck pans.
- ▶ Adjustable, heavy duty PVC coated shelves.
- ▶ Entire cabinet structure is foamed-in-place using Ecomate. A high density, polyurethane insulation that has zero ozone depletion potential (ODP) and zero global warming potential (GWP).

Exterior Color Options



Standard Black Exterior



Optional White Exterior

**STAINLESS
 PHOTO NOT YET
 AVAILABLE**

Optional Stainless Exterior

ROUGH-IN DATA

Specifications subject to change without notice.
 Chart dimensions rounded up to the nearest 1/8" (millimeters rounded up to next whole number).

Model	Shelves	Cabinet Dimensions (inches) (mm)			HP	Voltage	Amps	NEMA Config.	Cord Length (total ft.) (total m)	Crated Weight (lbs.) (kg)
		L	D	H						
TAC-30-LD	4	30 762	29 1/4 743	80 3/8 2048	3/4 N/A	115/60/1	15.1 N/A	5-20P	6.5 1.98	390 177



APPROVALS:

AVAILABLE AT:

Model:
TAC-30-LD

Vertical Air Curtains: Refrigerator with LED Lighting



STANDARD FEATURES

DESIGN

- Designed using the highest quality materials and components to provide the user with colder product temperatures and lower utility costs in an attractive merchandiser that brilliantly displays packaged food and beverages.

REFRIGERATION SYSTEM

- Factory engineered, self-contained, capillary tube system using environmentally friendly (CFC free) R404A refrigerant.
- Time-initiated, time-terminated off cycle defrost system.
- Extra large evaporator coil and condenser balanced with higher horsepower compressor; maintains cabinet temperatures of 35°F to 40°F (1.6°C to 4.4°C) for the best in food preservation.
- Sealed, cast iron, self-lubricating evaporator fan motors.
- Bottom mounted condensing unit positioned for easy maintenance.
- Patented reversing condenser fan motors. Fan motors reverse during defrost off cycles to help keep condenser coil free from dirt, dust and debris. Keeping coils clean optimizes the unit's performance providing colder holding temperatures and increased energy efficiency. Regularly scheduled thorough cleaning of coils still recommended.

CABINET CONSTRUCTION

- Exterior - durable and permanent non-peel or chip white vinyl front and sides with matching white aluminum back.
- Plexiglass lower front panel; durable and break resistant.
- Interior - attractive, NSF approved, white aluminum liner. Stainless steel interior floor and deck pans.

- Insulation - entire cabinet structure is foamed-in-place using a high density, polyurethane insulation that has zero ozone depletion potential (ODP) and zero global warming potential (GWP).
- Welded, heavy duty steel frame rail, black powder coated for corrosion protection.
- Frame rail fitted with leg levelers.
- Illuminated exterior sign panel. Variety of sign options available.

SHELVING

- Four (4) adjustable, heavy duty PVC coated wire shelves 25 1/16" L x 17 1/2" D (653 mm x 445 mm). Four (4) chrome plated shelf clips included per shelf.
- Shelf support pilasters made of same material as cabinet interior; shelves are adjustable on 1/2" (13 mm) increments.

LIGHTING

- LED interior lighting provides more even lighting throughout the cabinet. Safety shielded.

MODEL FEATURES

- Perforated interior back wall for more efficient airflow.
- Condensate pan heater/brackets kit.
- Listed under NSF/ANSI Standard 7 for the storage and/or display of packaged or bottled product.

ELECTRICAL

- Unit completely pre-wired at factory and ready for final connection to a 115V / 60 Hz single phase, 20 amp dedicated outlet. Cord and plug set included.



115/60/1
NEMA-5-20R

RECOMMENDED OPERATING CONDITIONS

- Designed to operate in an environment where temperature and humidity do not exceed 75°F (24°C) and 55% relative humidity.

- Unit should not be installed near HVAC vents, fans or doorways that will disrupt the air curtain and compromise the function of the cabinet. Unit should not be installed in direct sunlight.
- Model will run most efficiently when completely loaded with product.
- Drain plumbing hookup recommended. Condensate pan heater kit available if there is no access to drain plumbing. Condensate pan heater must be field installed and requires a separate 15 amp, 120V circuit.
- Please be advised Air Curtain models are substantially louder than standard refrigeration models.

OPTIONAL FEATURES/ACCESSORIES

Upcharge and lead times may apply.

- 2 1/2" (64 mm) diameter castors (set of 4).
- Variety of sign panels - see our website for the latest color and sign offerings.
- Black exterior.
- Stainless steel exterior.
- Black interior liner with black shelves.
- TrueFlex gravity feed organizers.
- White cantilevered shelves.
- Stainless steel cantilevered shelves.
- Pricing strips.
- Night shade.
- White locking security cover. Standard with flat sign panel. Adds 6 3/4" (171 mm) to cabinet height. (Factory Installed with some Field assembly required.)
- Silver locking security cover. Standard with flat sign panel. Adds 6 3/4" (171 mm) to cabinet height. (Factory Installed with some Field assembly required.)
- Black locking security cover. Standard with flat sign panel. Adds 6 3/4" (171 mm) to cabinet height. (Factory Installed with some Field assembly required.)

PLAN VIEW

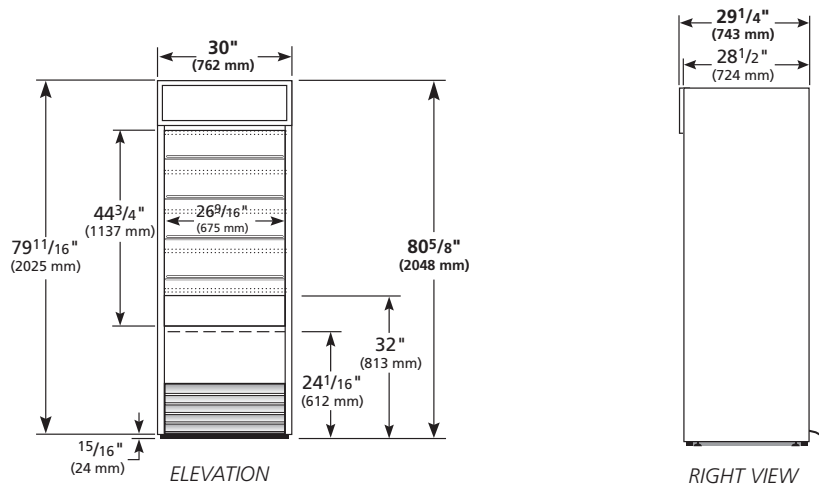

WARRANTY
Three year warranty on all parts and labor and an additional 2 year warranty on compressor. (U.S.A. only)

METRIC DIMENSIONS ROUNDED UP TO THE NEAREST WHOLE MILLIMETER
SPECIFICATIONS SUBJECT TO CHANGE WITHOUT NOTICE



Model	Elevation	Right	Plan	3D	Back
TAC-30-LD	TFD035E	TFD025S	TFD035P	TFD0353	

TRUE MANUFACTURING CO., INC.

2001 East Terra Lane • O'Fallon, Missouri 63366-4434 • (636)240-2400 • Fax (636)272-2408 • Toll Free (800)325-6152 • Intl. Fax# (001)636-272-7546 • www.truefmfg.com