



TRUE MANUFACTURING CO., INC.
U.S.A. FOODSERVICE DIVISION

2001 East Terra Lane • O'Fallon, Missouri 63366-4434 • (636)240-2400
Fax (636)272-2408 • Toll Free (800)325-6152 • Intl Fax# (001)636-272-7546
Parts Dept. (800)424-TRUE • Parts Dept. Fax# (636)272-9471 • www.truemfg.com

Project Name: _____

Location: _____

Item #: _____ Qty: _____

Model #: _____

A/A #

S/S #

Model:
TCGG-36-LD

Display Case:
Curved Glass Refrigerated Deli Case with LED Lighting



TCGG-36-LD

- ▶ True's curved glass deli case combines efficient, high volume merchandising and exceptional refrigeration with an elegant curved glass front for sophisticated presentation of deli products.
- ▶ High humidity gravity coil refrigeration system maintains 38°F to 40°F (3.3°C to 4.4°C) for the freshest display of meats, cheeses and deli products.
- ▶ Self-contained, environmentally friendly (CFC free) 134A refrigeration system.
- ▶ Cabinet is NSF/ANSI Standard 7 certified to hold open food product.
- ▶ Insulated double panel curved front glass provides maximum insulation value for greater efficiency and energy savings. Both panes are tempered for safety.
- ▶ Two (2) adjustable, lighted, cantilevered PVC coated shelves.
- ▶ LED lights are low UV emitting to enhance product appearance and increase shelf life.
- ▶ White laminated vinyl exterior. Stainless steel top and trim.
- ▶ White aluminum interior sides and top. Stainless steel floor with coved corners.

ROUGH-IN DATA

Specifications subject to change without notice.
Chart dimensions rounded up to the nearest 1/8" (millimeters rounded up to next whole number).

Model	Doors	Shelves	Cabinet Dimensions (inches) (mm)			HP	Voltage	Amps	NEMA Config.	Cord Length (total ft.) (total m)	Crated Weight (lbs.) (kg)
			W	D†	H						
TCGG-36-LD	2	2	36¼ 921	35¼ 896	47¾ 1213	1/3 N/A	115/60/1	12.0 N/A	5-15P	9 2.74	450 205

† Depth does not include 3/8" (23 mm) for door handles.



APPROVALS:

AVAILABLE AT:

Model:
TCGG-36-LD

Display Case:
Curved Glass Refrigerated Deli Case with LED Lighting



STANDARD FEATURES

DESIGN

- True's curved glass deli display case combines efficient, high volume merchandising and exceptional refrigeration with an elegant curved glass front for sophisticated presentation of deli products.
- Gravity coil refrigeration system guarantees the freshest display of meats, cheeses and deli products.

REFRIGERATION SYSTEM

- Factory engineered, self-contained, capillary tube system using environmentally friendly (CFC free) 134A refrigerant.
- Extra large evaporator coil balanced with higher horsepower compressor and large condenser maintains 38°F to 40°F (3.3°C to 4.4°C).
- High humidity gravity coil refrigeration system. Ideally suited for deli meats, cheeses and salads.
- Condensing unit located behind panel in back of unit. Entire system slides out for easy cleaning and maintenance.
- Automatic defrost system; time-initiated, time-terminated.

CABINET CONSTRUCTION

- Exterior - durable and permanent no peel or chip white laminated vinyl with stainless steel top and trim.
- Interior - NSF approved white aluminum sides and top. Stainless steel floor with coved corners.

- Insulation - entire cabinet structure is foamed-in-place using a high density, polyurethane insulation that has zero ozone depletion potential (ODP) and zero global warming potential (GWP).
- Welded, heavy duty steel frame rail, black powder coated for corrosion protection.
- Frame rail fitted with leg levelers.

CURVED FRONT DISPLAY GLASS

- Insulated double panel glass provides maximum insulation value for greater efficiency and energy savings. Both panes are tempered for safety.

REAR DOORS

- "Low-E", double pane thermal glass inserts with mitered plastic channel frames.
- Each door fitted with 12" (305 mm) long black aluminum handle.
- Self-closing doors. Sliding doors ride on stainless steel V-Channel with stainless steel bearings for smooth, even, positive closure. Doors fit within plastic channel frame.

SHELVING

- Two (2) adjustable, lighted, white heavy duty PVC coated wire shelves 30⁷/₈" L x 22⁵/₃₂" D (785 mm x 563 mm). Shelving system is cantilevered with adjustable angle to maximize presentation.

LIGHTING

- Cabinet equipped with three LED (3) light sources for maximum product display; two (2) shelf mounted and one (1) cabinet mounted.

MODEL FEATURES

- Evaporator is epoxy coated to eliminate the potential of corrosion.
- Four (4) amp exterior scale receptacle.
- NSF/ANSI Standard 7 compliant for open food product.

ELECTRICAL

- Unit completely pre-wired at factory and ready for final connection to a 115/60/1 phase, 15 amp dedicated outlet. Cord and plug set included.



115/60/1
NEMA-5-15R

RECOMMENDED OPERATING CONDITIONS

- TCGG refrigerated models are designed to operate in an environment where temperature and humidity do not exceed 75°F (24°C) and 55% relative humidity.

OPTIONAL FEATURES/ACCESSORIES

Upcharge and lead times may apply.

- 6" (153 mm) standard legs.
- 6" (153 mm) seismic/flanged legs.
- 2¹/₂" (64 mm) diameter castors.
- 4" (102 mm) diameter castors.
- Ratchet locks.
- Additional lighted shelf (maximum of 3 shelves per cabinet).
- Non-lighted shelves.
- Lighted stainless steel mezzanine shelves.
- Non-lighted stainless steel mezzanine shelves.

PLAN VIEW

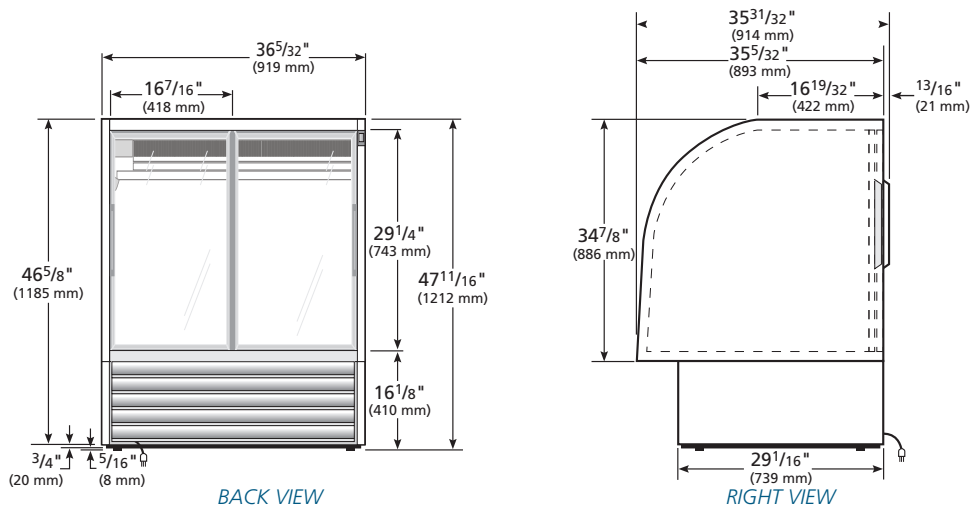

WARRANTY
Three year warranty on all parts and labor and an additional 2 year warranty on compressor. (U.S.A. only)

METRIC DIMENSIONS ROUNDED UP TO THE NEAREST WHOLE MILLIMETER
SPECIFICATIONS SUBJECT TO CHANGE WITHOUT NOTICE



Model	Elevation	Right	Plan	3D	Back
TCGG-36-LD	TFD047E	TFD047S	TFD047P	TFD0473	TFD047B

TRUE MANUFACTURING CO., INC.