



**TRUE FOOD SERVICE EQUIPMENT, INC.**

2001 East Terra Lane • O'Fallon, Missouri 63366-4434 • (636)240-2400  
 Fax (636)272-2408 • Toll Free (800)325-6152 • Intl Fax# (001)636-272-7546  
 Parts Dept. (800)424-TRUE • Parts Dept. Fax# (636)272-9471 • www.truemfg.com

Project Name: \_\_\_\_\_

Location: \_\_\_\_\_

Item #: \_\_\_\_\_ Qty: \_\_\_\_\_

Model #: \_\_\_\_\_

A/A #

SIS #

Model:  
**TFM-41FL-CFR**

**Horizontal Freezer:**  
*Glass Flat Lid Convertible Freezer/Refrigerator*



**TFM-41FL-CFR**

- ▶ True's horizontal convertible freezer/refrigerator units are uniquely designed to promote high-profit frozen or refrigerated novelties in high impulse retail traffic areas. Ideal for bolstering incremental sales of frozen and refrigerated merchandise and seasonal specialties.
- ▶ Cold wall refrigeration system. When set to freezer cabinet maintains -10° F (-23.33°C). When set to refrigerator cabinet maintains 33°F to 40°F (.5°C to 4.5°C) cabinet temperature.
- ▶ Exterior - non-peel or chip white laminated vinyl, durable and permanent; with gray mitered plastic top and lid frames.
- ▶ Interior - NSF approved, white aluminum with stainless steel floor.
- ▶ Tempered, hard coated, "Low-E" glass slide lids. Reduces solar heat gain, enhances energy efficiency and minimizes condensation.
- ▶ Locks standard, provide security, prevents theft.
- ▶ 2 1/2" (64 mm) diameter stem castors.
- ▶ Entire cabinet structure is foamed-in-place using Ecomate. A high density, polyurethane insulation that has zero ozone depletion potential (ODP) and zero global warming potential (GWP).

**ROUGH-IN DATA**

Specifications subject to change without notice.  
 Chart dimensions rounded up to the nearest 1/8" (millimeters rounded up to next whole number).

Model	Lids	Cabinet Dimensions (inches) (mm)			HP	Voltage	Amps	NEMA Config.	Cord Length (total ft.) (total m)	Crated Weight (lbs.) (kg)
		L	D	H*						
TFM-41FL-CFR	2	41 3/8 1051	26 1/8 664	31 5/8 804	1/4 N/A	115/60/1	2.5 N/A	5-15P	9 2.74	190 87

\* Height does not include 3/4" (83 mm) for castors & 7/8" (23mm) for lid handle.

	<p><b>APPROVALS:</b></p>	<p><b>AVAILABLE AT:</b></p>
<p>5/15 Printed in U.S.A.</p>		

Model:  
**TFM-41FL-CFR**

**Horizontal Freezer:**  
*Glass Flat Lid Convertible Freezer/Refrigerator*



**STANDARD FEATURES**

**DESIGN**

- True's horizontal convertible freezer/refrigerator units are uniquely designed to promote high-profit frozen or refrigerated novelties in high impulse retail traffic areas. Ideal for bolstering incremental sales of frozen and refrigerated merchandise and seasonal specialties.

**REFRIGERATION SYSTEM**

- Factory engineered, self-contained, capillary tube system using environmentally friendly (CFC free) 134A refrigerant.
- Cold wall refrigeration system. When set to freezer cabinet maintains -10° F (-23.33°C). When set to refrigerator cabinet maintains 33°F to 40°F (.5°C to 4.5°C) cabinet temperature.
- Condensing unit is accessed from behind grill on right side; slides out for easy maintenance.
- Manual defrost system; convenient drain located on front of cabinet.

**CABINET CONSTRUCTION**

- Exterior - non-peel or chip white laminated vinyl, durable and permanent; with gray mitered plastic top and lid frames.
- Interior - attractive, NSF approved, white aluminum liner; non-rust, peel or chip. Stainless steel floor.
- Insulation - entire cabinet structure is foamed-in-place using Ecomate. A high density, polyurethane insulation that has zero ozone depletion potential (ODP) and zero global warming potential (GWP).
- 2 1/2" (64mm) diameter stem castors.

**LIDS**

- Tempered, hard coated, "Low-E", single pane glass slide lid assemblies. The latest in energy efficient technology; reduces solar heat gain and minimizes condensation.
- Designed for convenient access, fast service and attractive display.
- Lid lock standard.

**MODEL FEATURES**

- Self-contained, portable system. No plumbing required.

- Low profile design permits easier placement, saves aisle space.
- Interior mounted thermometer.
- NSF-7 compliant for open food product.

**ELECTRICAL**

- Unit completely pre-wired at factory and ready for final connection to a 115/60/1 phase, 15 amp dedicated outlet. Cord and plug set included.



115/60/1  
NEMA-5-15R

**RECOMMENDED OPERATION CONDITIONS**

- Designed to operate in an environment where temperature and humidity do not exceed 75°F (24°C) and 55% relative humidity.

**OPTIONAL FEATURES/ACCESSORIES**

Upcharge and lead times may apply.

- Black vinyl exterior.
- Heavy duty novelty baskets (accommodates 3).
- Dividers for novelty baskets.

**PLAN VIEW**

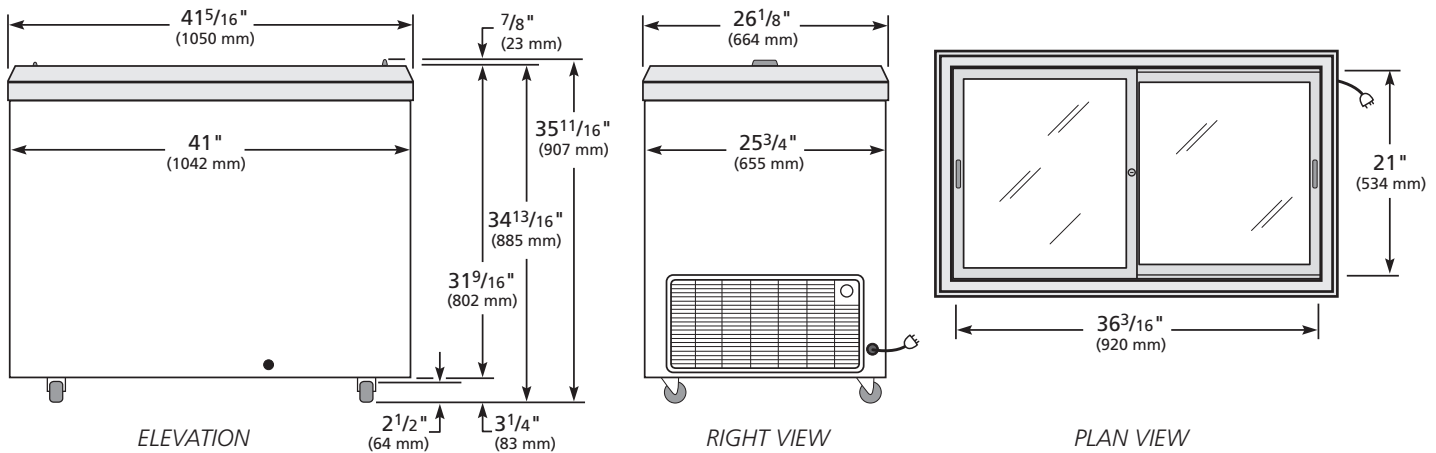

**WARRANTY\***  
 Three year warranty on all parts and labor and an additional 2 year warranty on compressor. (U.S.A. only)

METRIC DIMENSIONS ROUNDED UP TO THE NEAREST WHOLE MILLIMETER

SPECIFICATIONS SUBJECT TO CHANGE WITHOUT NOTICE



Model	Elevation	Right	Plan	3D	Back
TFM-41FL-CFR	TFEY79E	TFEY78S	TFEY79P	TFEY793	TFEY79B

**TRUE FOOD SERVICE EQUIPMENT**

\*RESIDENTIAL APPLICATIONS: TRUE assumes no liability for parts or labor coverage for component failure or other damages resulting from installation in non-commercial or residential applications.