



**TRUE FOOD SERVICE EQUIPMENT, INC.**

St. Charles Industrial Center • P.O. Box 970 • O'Fallon, Missouri 63366  
 (636)240-2400 • FAX (636)272-2408 • (800)325-6152 • www.truemfg.com  
 Parts Dept. (800)424-TRUE • Parts Dept. FAX# (636)272-9471

Project Name: \_\_\_\_\_

A/A #

Location: \_\_\_\_\_

Item #: \_\_\_\_\_ Qty: \_\_\_\_\_

SIS #

Model #: \_\_\_\_\_

Model:  
**TG2F-2G**

**TG Series:**  
*Reach-In Glass Door Freezer*



**TG2F-2G**

- ▶ Designed using the highest quality materials and components to provide the user with colder product temperatures, lower utility costs and exceptional food safety.
- ▶ Oversized, factory balanced, refrigeration system holds -10°F (-23.33°C) for the best in food preservation.
- ▶ 300 series stainless steel doors and front. Anodized quality aluminum exterior sides, back and bottom.
- ▶ NSF approved, white aluminum interior liner. 300 series stainless steel door liner and floor with coved corners.
- ▶ Adjustable, heavy duty, PVC coated shelves.
- ▶ Positive seal self-closing doors. Lifetime guaranteed door hinges and torsion type closure system.
- ▶ Entire cabinet structure is foamed-in-place using high density, CFC free, polyurethane insulation.
- ▶ Automatic defrost system time-initiated, temperature-terminated. Saves energy consumption and provides shortest possible defrost cycle.

**ROUGH-IN DATA**

Specifications subject to change without notice.

Chart dimensions rounded up to the nearest 1/8" (millimeters rounded up to next whole number).

Model	Solid Doors	Capacity (Cu. Ft.) (liters)	# of Shelves	Cabinet Dimensions (inches) (mm)			HP	Voltage	Amps	NEMA Config.	Cord Length (total ft.) (total m)	Crated Weight (lbs.) (kg)
				L	D†	H*						
TG2F-2G	2		6	51 <sup>3</sup> / <sub>8</sub> 1305	34 <sup>7</sup> / <sub>8</sub> 886	78 <sup>1</sup> / <sub>4</sub> 1988	1	115/208-230	9.1	14-20	9 2.74	N/A N/A

† Depth does not include 1<sup>3</sup>/<sub>8</sub>" (35 mm) for door handles.

\* Height does not include 5" (127 mm) for castors and 1" (26 mm) for system mechanical components.



**APPROVALS:**

Model:  
**TG2F-2G**

**TG Series:**  
Reach-In Glass Door Freezer



## STANDARD FEATURES

### DESIGN

- True's glass door reach-in's are designed with enduring quality that protects your long term investment.
- Designed using the highest quality materials and components to provide the user with colder product temperatures, lower utility costs and exceptional food safety.

### REFRIGERATION SYSTEM

- Factory engineered, self-contained, capillary tube system using environmentally friendly (CFC free) 404A refrigerant.
- Extra large evaporator coil balanced with higher horsepower compressor and large condenser maintains -10°F (-23.3°C) cabinet temperature. Ideal for both frozen foods and ice cream.
- Sealed, cast iron, self-lubricating evaporator fan motors and larger fan blades give True reach-in's a more efficient low velocity, high volume airflow design. This unique design insures faster temperature recovery and shorter run times in the busiest of foodservice environments.
- Top mounted refrigeration system with evaporator positioned out of food zone to maximize capacity.
- Automatic defrost system time-initiated, temperature-terminated. Saves energy consumption and provides shortest possible defrost cycle.

### CABINET CONSTRUCTION

- Exterior - 300 series stainless steel doors and front Anodized quality aluminum sides, back and bottom.
- Interior- white aluminum side walls and back liner. 300 series stainless floor with coved corners.
- Insulation - entire cabinet structure is foamed-in-place using high density, CFC free, polyurethane insulation.

- Welded, heavy duty galvanized frame rail dipped in rust inhibiting enamel paint for corrosion protection inside and out.
- Frame rail fitted with 4" (102 mm) diameter stem castors - locks provided on front set.

### DOORS

- Triple pane thermal glass assemblies with extruded aluminum frames. Doors open within cabinet dimension. Door locks standard.
- Positive seal self-closing doors with 90° stay open feature. Lifetime guaranteed door hinges.
- Each door fitted with 15" (381 mm) long extruded aluminum handle.
- Magnetic door gaskets of one piece construction, removable without tools for ease of cleaning.

### SHELVING

- Six (6) adjustable, heavy duty, PVC coated wire shelves 25" L x 27<sup>3</sup>/<sub>4</sub>" D (635 mm x 705 mm) (shipped separately). Four (4) shelf supports included per shelf. Shelves adjustable on 6" (153 mm) increments.
- Four (4) different interior kits available (see kit options). Pilasters and tray slides require field installation. (shipped separately).

### LIGHTING

- Incandescent interior lighting - lights activated by rocker switch mounted above doors, safety shielded.

### MODEL FEATURES

- Exterior mounted digital temperature monitor.
- Evaporator is epoxy coated to eliminate the potential of corrosion
- Backguard improves airflow.
- Minimum wattage heater in cabinet frame and door.

### ELECTRICAL

- Unit completely pre-wired at factory and ready for final connection to a 115/208-230/60Hz single phase, 3 pole, 4 wire - 20 amp dedicated outlet. Cord and plug set included.



115/208-230/1  
NEMA-14-20R

### OPTIONAL FEATURES/ACCESSORIES

Upcharge and lead times may apply.

- 6" (153 mm) standard legs.
- 6" (153 mm) seismic/flanged legs.
- 6" (153 mm) stainless steel legs.
- Additional shelves.
- Electronic temperature control (factory installed).
- Curb mountable units.
- Remote cabinets (condensing unit supplied by others), consult factory technical service department for BTU information.

### KIT OPTIONS

- Kit #1: Nine (9) sets of #1 type tray slides (factory installed), bottom support of (1) 18" L x 26" D (458 mm x 661 mm) pan or (2) 14" L x 18" D (356 mm x 458 mm) pans.
- Kit #2: One (1) set half-section #2 steel rod tray slides (factory installed), rim support of (1) 18" L x 26" D (458 mm x 661 mm) pan.
- Kit #3: Six (6) sets of universal type tray slides (factory installed), bottom support of (1) 18" L x 26" D (458 mm x 661 mm) pan, (2) 12" L x 20" D (305 mm x 508 mm) pans or (2) 14" L x 18" D (356 mm x 458 mm) pans.
- Kit #4: Three (3) chrome shelves 25" L x 27<sup>3</sup>/<sub>4</sub>" D (635 mm x 705 mm). Four (4) shelf supports included per shelf. Shelves adjustable on 6" (153 mm) increments.
- Additional kit option components available individually.

## PLAN VIEW

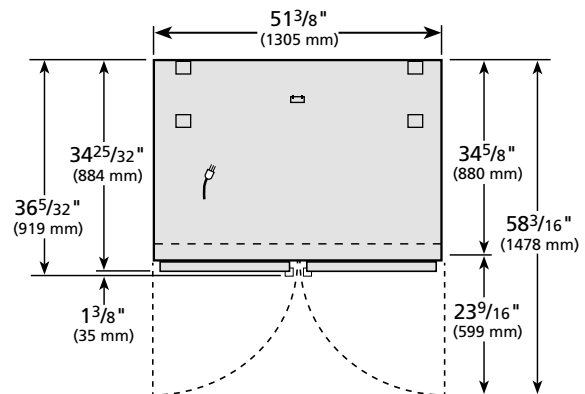
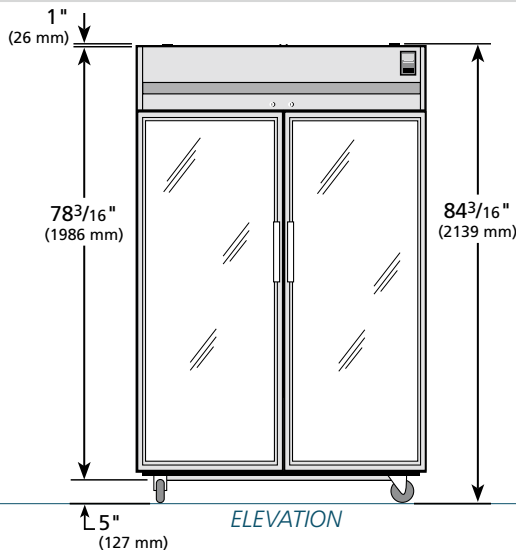

### WARRANTY

One year warranty on all parts and labor and an additional 4 year warranty on compressor. (U.S.A. only)

METRIC DIMENSIONS ROUNDED UP TO THE NEAREST WHOLE MILLIMETER

SPECIFICATIONS SUBJECT TO CHANGE WITHOUT NOTICE



Model	Elevation	Right	Plan	3D
TG2F-2G				

## TRUE FOOD SERVICE EQUIPMENT

St. Charles Industrial Center • P.O. Box 970 • O'Fallon, Missouri 63366 • (636)240-2400 • FAX (636)272-2408 • (800)325-6152 • www.truemfg.com