



**TRUE MANUFACTURING CO., INC.**  
**U.S.A. FOODSERVICE DIVISION**

2001 East Terra Lane • O'Fallon, Missouri 63366-4434 • (636)240-2400  
 Fax (636)272-2408 • Toll Free (800)325-6152 • Intl Fax# (001)636-272-7546  
 Parts Dept. (800)424-TRUE • Parts Dept. Fax# (636)272-9471 • www.truemfg.com

Project Name: \_\_\_\_\_

Location: \_\_\_\_\_

Item #: \_\_\_\_\_ Qty: \_\_\_\_\_

Model #: \_\_\_\_\_

A/A #

SIS #

Model:  
**TUC-36-ADA-HC~SPEC1**

**Undercounter:**

*ADA Compliant Solid Door Refrigerator with Hydrocarbon Refrigerant~Spec Package 1*



**TUC-36-ADA-HC~SPEC1**

- ▶ True's undercounter units are designed with enduring quality that protects your long term investment.
- ▶ Designed using the highest quality materials and components to provide the user with colder product temperatures, lower utility costs, exceptional food safety and the best value in today's food service marketplace.
- ▶ Factory engineered, self-contained, capillary tube system using environmentally friendly R290 hydro carbon refrigerant that has zero (0) ozone depletion potential (ODP), & three (3) global warming potential (GWP).
- ▶ 3" (77 mm) diameter stem castors standard. 34" (864 mm) work surface height. Complies with the Americans with Disabilities Act (ADA) requirements.
- ▶ High capacity, factory balanced refrigeration system that maintains cabinet temperatures of 33°F to 38°F (.5°C to 3.3°C) for the best in food preservation.
- ▶ Stainless steel front, countertop, sides, and back.
- ▶ Interior - Stainless steel liner. Stainless steel floor with coved corners.
- ▶ Heavy duty 16 gauge top and 20 gauge doors.
- ▶ Lifetime guaranteed heavy duty all metal working spec door handle.
- ▶ Counter-Top front is flush with front of doors.
- ▶ Electronic temperature control with digital display.
- ▶ Foamed-in-place using a high density, polyurethane insulation that has zero ozone depletion potential (ODP) and zero global warming potential (GWP).
- ▶ Spec Series® logo.

**ROUGH-IN DATA**

Specifications subject to change without notice.  
 Chart dimensions rounded up to the nearest 1/8" (millimeters rounded up to next whole number).

| Model               | Doors | Shelves | Cabinet Dimensions (inches) (mm) |               |               | HP         | Voltage  | Amps       | NEMA Config. | Cord Length (total ft.) (total m) | Crated Weight (lbs.) (kg) |
|---------------------|-------|---------|----------------------------------|---------------|---------------|------------|----------|------------|--------------|-----------------------------------|---------------------------|
|                     |       |         | L                                | D†            | H*            |            |          |            |              |                                   |                           |
| TUC-36-ADA-HC~SPEC1 | 2     | 4       | 36 3/8<br>924                    | 29 1/8<br>740 | 29 3/4<br>756 | 1/8<br>N/A | 115/60/1 | 2.0<br>N/A | 5-15P        | 7<br>2.13                         | TBD<br>TBD                |

† Depth does not include 1 1/2" (39 mm) for door handles.

‡ Depth does not include 1" (26 mm) for rear bumpers.

\*Height does not include 4" (102 mm) for castors.

|  |                   |                      |
|--|-------------------|----------------------|
|  | <b>APPROVALS:</b> | <b>AVAILABLE AT:</b> |
|  | 6/18-A            | Printed in U.S.A.    |

Model:  
TUC-36-ADA-HC~SPEC1

**Undercounter:**  
ADA Compliant Solid Door Refrigerator with  
Hydrocarbon Refrigerant~Spec Package 1



**STANDARD FEATURES**

**DESIGN**

- True's undercounter units are designed with enduring quality that protects your long term investment.
- True's commitment to using the highest quality materials and oversized refrigeration systems provides the user with colder product temperatures, lower utility costs, exceptional food safety and the best value in today's food service marketplace.

**REFRIGERATION SYSTEM**

- Factory engineered, self-contained, capillary tube system using environmentally friendly R290 hydro carbon refrigerant that has zero (0) ozone depletion potential (ODP), & three (3) global warming potential (GWP).
- Energy efficient, factory balanced refrigeration system with guided airflow to provide uniform product temperatures.
- High capacity, factory balanced refrigeration system that maintains cabinet temperatures of 33°F to 38°F (.5°C to 3.3°C) for the best in food preservation.
- State of the art, electronically commutated evaporator and condenser fan motors. ECM motors operate at higher peak efficiencies and move a more consistent volume of air which produces less heat, reduces energy consumption and provides greater motor reliability.
- Condensing unit access in back of cabinet, slides out for easy maintenance.

**CABINET CONSTRUCTION**

- Exterior - stainless steel front, top, sides, and back.
- Interior - Stainless steel liner. Stainless steel floor with coved corners.
- Insulation - entire cabinet structure and solid doors are foamed-in-place using a high density, polyurethane insulation that has zero ozone depletion potential (ODP) and zero global warming potential (GWP).
- 3" (77 mm) diameter stem castors. 34" (864 mm) work surface height. Compliant with American Disabilities Act (ADA) requirements.

**DOORS**

- Stainless steel exterior with clear coated aluminum liner to match cabinet interior.
- door lock standard.
- Lifetime guaranteed heavy duty all metal working spec door handles.
- Positive seal self-closing doors with 90° stay open feature. Doors swing within cabinet dimensions.
- Magnetic door gaskets of one piece construction, removable without tools for ease of cleaning.

**SHELVING**

- Four (4) adjustable, heavy duty PVC coated wire shelves 15 5/16"L x 16"D (396 mm x 407 mm). Four (4) chrome plated shelf clips included per shelf.
- Shelf support pilasters made of same material as cabinet interior; shelves are adjustable on 1/2" (13 mm) increments.

**MODEL FEATURES**

- Evaporator is epoxy coated to eliminate the potential of corrosion.
- Heavy duty 16 gauge top and 20 gauge doors.
- Counter-Top front is flush with front of doors.
- Electronic temperature control with digital display.
- Spec Series® logo.
- NSF/ANSI Standard 7 compliant for open food product.

**ELECTRICAL**

- Unit completely pre-wired at factory and ready for final connection to a 115/60/1 phase, 15 amp dedicated outlet. Cord and plug set included.



115/60/1  
NEMA-5-15R

**OPTIONAL FEATURES/ACCESSORIES**

Upcharge and lead times may apply.

- Single overshelf.
- Double overshelf.
- 30" (762 mm) deep, 1/2" (13 mm) thick, white polyethylene cutting board. Requires "L" brackets.
- 30" (762 mm) deep, 1/2" (13 mm) thick, composite cutting board. Requires "L" brackets.
- Standard height units with 5" (127 mm) diameter castors. 36" (915 mm) work surface height.
- Low profile models with 31 7/8" (810 mm) work surface height.

**PLAN VIEW**

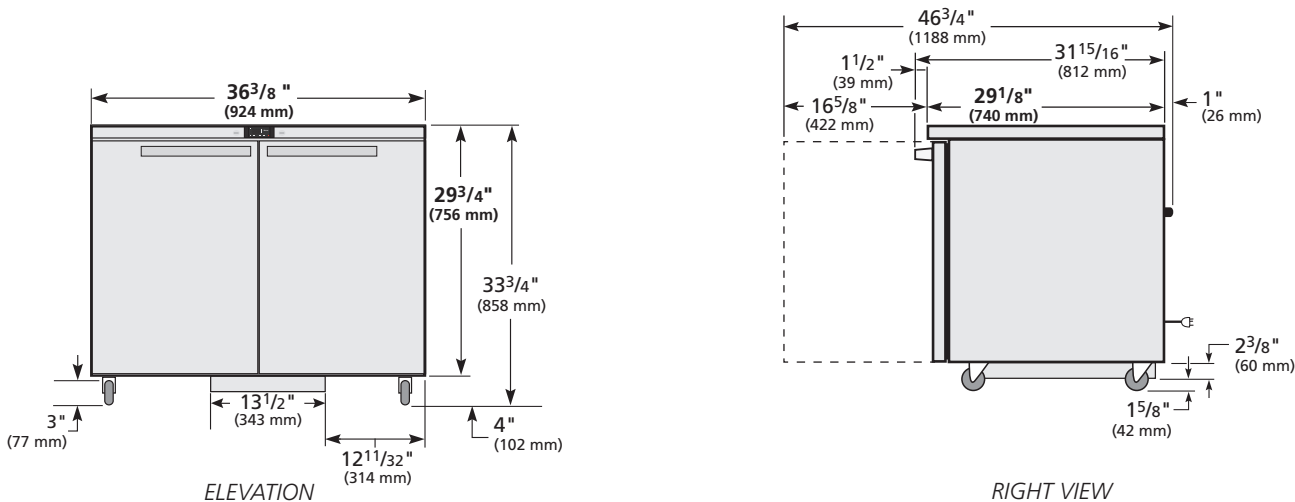

**WARRANTY**  
Three year warranty on all parts and labor and an additional 2 year warranty on compressor. (U.S.A. only)

METRIC DIMENSIONS ROUNDED UP TO THE NEAREST WHOLE MILLIMETER  
SPECIFICATIONS SUBJECT TO CHANGE WITHOUT NOTICE



|                     |           |       |      |    |      |
|---------------------|-----------|-------|------|----|------|
| Model               | Elevation | Right | Plan | 3D | Back |
| TUC-36-ADA-HC~SPEC1 |           |       |      |    |      |

**TRUE MANUFACTURING CO., INC.**