



TRUE MANUFACTURING CO., INC.
U.S.A. FOODSERVICE DIVISION

2001 East Terra Lane • O'Fallon, Missouri 63366-4434 • (636)240-2400
Fax (636)272-2408 • Toll Free (800)325-6152 • Intl Fax# (001)636-272-7546
Parts Dept. (800)424-TRUE • Parts Dept. Fax# (636)272-9471 • www.truemfg.com

Project Name: _____

Location: _____

Item #: _____ Qty: _____

Model #: _____

A/A #

S/S #

Model:

TUC-48D-4-LP-HC~SPEC1

Undercounter:

Low Profile Drawered Refrigerator with Hydrocarbon Refrigerant & Spec

TUC-48D-4-LP-HC~SPEC 1



- ▶ True's undercounter units are designed with enduring quality that protects your long term investment.
- ▶ Designed using the highest quality materials and components to provide the user with colder product temperatures, lower utility costs, exceptional food safety and the best value in today's food service marketplace.
- ▶ Factory engineered, self-contained, capillary tube system using environmentally friendly R290 hydro carbon refrigerant that has zero (0) ozone depletion potential (ODP), & three (3) global warming potential (GWP).
- ▶ 1 ½" (39 mm) diameter dual swivel castors. 31 ⅞" (810 mm) work surface height. "Low Profile" models are designed to slide easily under custom built countertops.
- ▶ High capacity, factory balanced refrigeration system that maintains cabinet temperatures of 33°F to 38°F (.5°C to 3.3°C) for the best in food preservation.
- ▶ Stainless steel front, countertop, sides, and back.
- ▶ Interior - Stainless steel liner. Stainless steel floor with coved corners.
- ▶ Heavy duty 16 gauge top and 20 gauge drawers.
- ▶ Lifetime guaranteed heavy duty all metal working spec door handle.
- ▶ Counter-Top front is flush with front of drawers.
- ▶ Electronic temperature control with digital display.
- ▶ Foamed-in-place using a high density, polyurethane insulation that has zero ozone depletion potential (ODP) and zero global warming potential (GWP).
- ▶ Spec Series® logo.

ROUGH-IN DATA

Specifications subject to change without notice.
Chart dimensions rounded up to the nearest 1/8" (millimeters rounded up to next whole number).

Model	Drawers	Cabinet Dimensions (inches) (mm)			HP	Voltage	Amps	NEMA Config.	Cord Length (total ft.) (total m)	Crated Weight (lbs.) (kg)
		W	D†	H*						
TUC-48D-4-LP-HC~SPEC1	4	48 ⅜ 1229	29 ⅞ 740	29 ¾ 756	1/5 1/4	115/60/1 230-240/50/1	3.0 1.63	5-15P ▲	7 2.13	N/A N/A

† Depth does not include 1 ½" (39 mm) for drawer handles.

† Depth does not include 1" (26 mm) for rear bumpers.

* Height does not include 2 ½" (54 mm) for castors.

▲ Plug type varies by country.



APPROVALS:

AVAILABLE AT:

6/18-A

Printed in U.S.A.

Model:
TUC-48D-4-LP-HC~SPEC1

Undercounter:
Low Profile Drawered Refrigerator with
Hydrocarbon Refrigerant & Spec Package 1



STANDARD FEATURES

DESIGN

- True's undercounters are designed with enduring quality and value that protects your long term investment. Our commitment to using the highest quality materials and oversized refrigeration ensures exceptional food preservation.
- "Low Profile" models are designed to slide easily under custom built countertops.

REFRIGERATION SYSTEM

- Factory engineered, self-contained, capillary tube system using environmentally friendly R290 hydro carbon refrigerant that has zero (0) ozone depletion potential (ODP), & three (3) global warming potential (GWP).
- Energy efficient, factory balanced refrigeration system with guided airflow to provide uniform product temperatures.
- High capacity, factory balanced refrigeration system that maintains cabinet temperatures of 33°F to 38°F (.5°C to 3.3°C) for the best in food preservation.
- State of the art, electronically commutated evaporator and condenser fan motors. ECM motors operate at higher peak efficiencies and move a more consistent volume of air which produces less heat, reduces energy consumption and provides greater motor reliability.
- Condensing unit access in back of cabinet, slides out for easy maintenance.

CABINET CONSTRUCTION

- Exterior - stainless steel front, top, sides, and back.
- Interior - Stainless steel liner. Stainless steel floor with coved corners.
- Insulation - entire cabinet structure and drawer facings are foamed-in-place using a high density, polyurethane insulation that has zero ozone depletion potential (ODP) and zero global warming potential (GWP).
- 1½" (39mm) diameter dual swivel castors permit easy placement. 3 1⁄8" (810 mm) work surface height.

DRAWERS

- Stainless steel exterior drawer facings and liners. Stainless steel drawer frames.
- Each drawer fitted with Lifetime guaranteed heavy duty all metal working spec handle.
- Heavy-duty stainless steel drawer slides and rollers. Removable without tools for easy cleaning.
- Magnetic drawer gaskets of one piece construction, removable without tools for ease of cleaning.
- Each drawer accommodates one (1) full size 12"L x 18"W x 6"D (305 mm x 458 mm x 153 mm) food storage box or one 1/3 size and one 1/2 size pan (sold separately).

MODEL FEATURES

- Evaporator is epoxy coated to eliminate the potential of corrosion.
- Heavy duty 16 gauge top.

- Counter-Top front is flush with front of drawers.
- Electronic temperature control with digital display.
- Spec Series® logo.
- NSF/ANSI Standard 7 compliant for open food product.

ELECTRICAL

- Unit completely pre-wired at factory and ready for final connection to a 115/60/1 phase, 15 amp dedicated outlet. Cord and plug set included.



115/60/1
NEMA-5-15R

OPTIONAL FEATURES/ACCESSORIES

Upcharge and lead times may apply.

- 230 - 240V / 50 Hz.
- Single overshelf.
- Double overshelf.
- 30" (762 mm) deep, 1/2" (13 mm) thick, white polyethylene cutting board. Requires "L" brackets.
- 30" (762 mm) deep, 1/2" (13 mm) thick, composite cutting board. Requires "L" brackets.
- Standard height units with 5" (127 mm) diameter castors. 36" (915 mm) work surface height.
- ADA compliant models with 34" (864 mm) work surface height.

PLAN VIEW

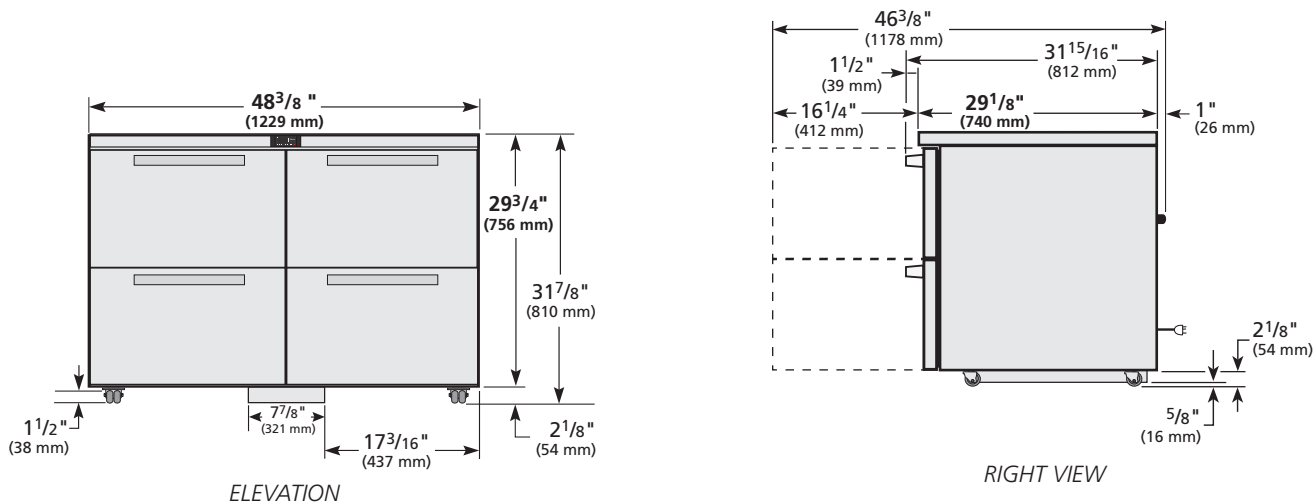

WARRANTY
Three year warranty on all parts and labor and an additional 2 year warranty on compressor. (U.S.A. only)

METRIC DIMENSIONS ROUNDED UP TO THE NEAREST WHOLE MILLIMETER
SPECIFICATIONS SUBJECT TO CHANGE WITHOUT NOTICE



Model	Elevation	Right	Plan	3D	Back
TUC-48D-4-LP-HC-SPEC1					

TRUE MANUFACTURING CO., INC.