

Water filter system

accessory



Filter system compatibility	Capacity – gal (l)	Item number
Symphony™ & Symphony Plus™ ice and water dispensers, Maestro™ & Maestro Plus™ Chewblet® ice machines	standard – 3,000 (11,340)	00130229
Symphony & Symphony Plus ice and water dispensers, Maestro & Maestro Plus Chewblet ice machines, Horizon™ Chewblet ice machines	high capacity – 15,000 (56,700)	00978957

Replacement cartridge description	Unit	Item number
primary filter, standard capacity	carton of 6	00954297
	single	00130245
primary filter, high capacity	carton of 6	00978973
	single	00978965
pre-filter	carton of 12	00954305
	single	00130211

Features

Includes Agion® silver-based antimicrobial product protection of key water contact components¹

Two capacities to choose – 3,000 or 15,000 gallon (11,340 or 56,700 liter)

System includes pre-filter, primary filter, pressure gauge and wall mounting bracket

Better tasting, cleaner, ice and water

- includes Micro-pure® II media (00130229) or Fibredyne® media (00978957), both featuring Agion antimicrobial product protection to inhibit the growth of biofilm and enhance filter performance¹
- traps dirt as small as 0.5 micron in size
- removes chlorine, off-tastes and odors
- advanced filtration system filters out parasitic cysts
- certified to ANSI/NSF standards 42 and 53

Improves ice machine performance

- dramatically reduces the most common water-related ice machine problems to keep ice machines functioning at full capacity
- reduces scale build-up from dirt and minerals in the water
- removes dirt and abrasive particles that can damage ice machine
- saves energy and reduces downtime

Space-saving design

- Both systems can be mounted in areas as small as 14.75" (45.0 cm) wide by 21.00" (53.3 cm) high or out of the way below standard 34.00" - 36.00" (86.4 cm - 91.4 cm) counters

Pre-filter system saves money

- economical 10 micron pre-filter filters out large particles and extends life of primary filter

Job

Item

Specification

W1 Width	14.25" (36.2 cm)
Depth	6.00" (15.24 cm)
H1 Height	18.50" (47.0 cm)
Service clearance	2.50" (6.35 cm) at bottom for cartridge removal
C1 Water inlet	3/4" FNPT (3/8" reducer bushing included with system)
C2 Water outlet	3/8" FNPT
C3 Pre-filter	10 micron capable
C4 Primary filter	0.5 micron
C5 Flushing valve	
Capacity	Standard – 3,000 gal (11,340 l) High capacity – 15,000 gal (56,700 l)
Flow rate	0.5 gpm (1.9 lpm)
Water temperature	40 - 90 F (5 - 32 C)
Water pressure	10 - 125 psi (69 - 860 kpa) Standard – 0.59 gpm High capacity – 2.59 gpm
NSF International ISS capable standard no. 42 NOTE: Contact Follett to obtain confirmation of the specific model numbers covered by this certification	Aesthetic effects – Chemical reduction: taste & odor and chlorine reduction, Mechanical filtration: particulate reduction, class 1: 99.9% reduction of particles 0.5 micron and larger in size
NSF International standard no. 53 NOTE: Contact Follett to obtain confirmation of the specific model numbers covered by this certification	Health effects – Mechanical filtration: Cyst reduction, Turbidity reduction (high capacity, item# 00978957, only)
Approximate ship weight	15 lb (7 kg)

NOTE: For indoor use only. Check for compliance with state and local laws and regulations. Do not use any filtration system where the water is microbiologically unsafe or with water of unknown quality without adequate disinfection before or after the unit. May be used with disinfected water where filterable cysts may be present.

Dimensional drawing

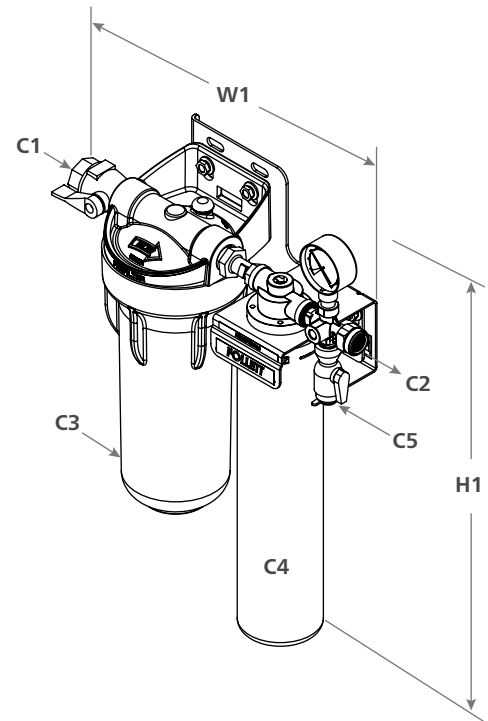

Agion is a registered trademark of Sciesent LLC.

1 Disclaimer: Antimicrobial protection is limited to the treated components and does not treat water.

Everpure and Micro-Pure II are registered trademarks of Everpure, a division of Pentair Foodservice. Fibredyne is a trademark of Pentair Filtration Solutions, LLC, Hanover Park, IL, USA. Horizon, Maestro, Maestro Plus, Symphony and Symphony Plus are trademarks of Follett Corporation. Chewblet and Follett are registered trademarks of Follett Corporation, registered in the US. Follett reserves the right to change specifications at any time without obligation. Certifications may vary depending on country of origin.

Water filter system accessory