

Symphony™ ice and water dispenser with Chewblet® ice machine

110 CT series countertop



SensorSAFE infrared dispense (optional)



Ice and water dispensers				
Ice storage capacity	Dispense	Ice machine cooling	Voltage V/Hz	Item number
90 lb (40.8 kg)	lever	air	115/60	110CT400A-L
			220/60	C110CT400A-L
			230/50	E110CT400A-L
		water	115/60	110CT400W-L
			220/60	C110CT400W-L
			230/50	E110CT400W-L
	SensorSAFE	air	115/60	110CT400A-S
			220/60	C110CT400A-S
water		115/60	110CT400W-S	
		220/60	C110CT400W-S	
		230/50	E110CT400W-S	

Ice-only available (115 V/ 60 Hz – air-cooled only), add -SI or -LI
Example: 110CT400A-LI

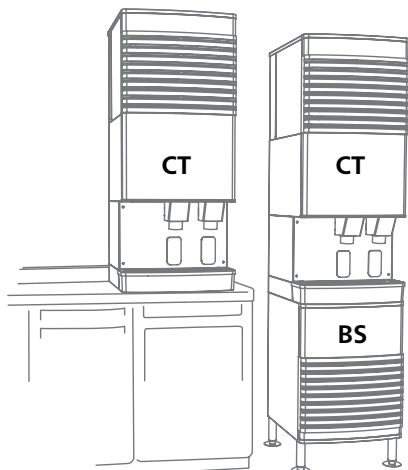

Features

90 lb (40.8 kg) ice storage capacity

Removable air- or water-cooled ice machine with up to 400 lb (181.4 kg) daily production of popular Chewblet ice

- soft, chewable, compressed nugget ice is preferred over cubes¹ and is ideal for patient care
- environmentally responsible R404a refrigerant with zero ozone depletion potential
- water and energy efficient
- stainless steel evaporator and auger
- quiet production without noisy harvest cycles

Durable, attractive dispenser

- stainless steel exterior with accent trim
- smooth contours for aesthetically appealing appearance
- corrosion-resistant poly drain pan and dispenser lid

Designed with sanitation in mind

- Agion® silver-based antimicrobial product protection of key ice and water contact components²
- one-hand lever or SensorSAFE™ infrared ice dispense reduces the chance of cross-contamination
- SensorSAFE not recommended for use with clear containers or for applications in direct sunlight

Installation

- comes in two boxes – ice machine and dispenser

Warranty

- 3 years parts and labor, 5 years compressor parts

Accessories

- BS** – Base stand (item# AF110BASESTD)
- Chilled water option (item# AFH2OCHIL110)
- Water filter kit (item# 00130229)
- High capacity water filter kit (item# 00978957)
- Carbonless water filter kit (item# 01050442)
- SafeCLEAN™ environmentally responsible ice machine cleaner (item# 00132001)
- Nu-Calgon® IMS-II sanitizer, 16 oz bottle (item# 00979674)

Job _____

Item _____

Follett Europe Polska Sp. z o.o.
Mokry Dwór 26C 83-021 Wiślina, Poland
+48 (58) 785-6140 | Fax: +48 (58) 785-6159
folletteurope.com

801 Church Lane | Easton, PA 18040, USA
1.610.252.7301 | Fax: +1.610.250.0696 | follettice.com

FOLLETT[®]
Innovative solutions, inspired by ice

Specification

Ice storage capacity	90 lb (40.8 kg)
W1 Width	24.50" (62.23 cm)
W2 Width, base stand accessory	26.00" (66.0 cm)
D1 Depth	27.88" (70.8 cm)
D2 Depth, drain pan	7.00" (17.78 cm)
D3 Depth, base stand accessory	29.00" (73.7 cm)
H1 Height	52.75" (134.0 cm)
H2 Dispense height clearance	7.62" (19.35 cm)
H3 Height, base stand accessory	33.00" (83.8 cm)
Ventilation clearance	air-cooled models only – 6.00" (15.24 cm) top
Service clearance	12.00" (30.5 cm) top
C1 115 V/60/1 dispenser electrical	14 amps, max. fuse 20 amps. 7' (2.1 m) cord, NEMA 5-20 90° hospital-grade plug.
C2 220 V/60/1 ("C" models) / 230 V/50/1 ("E" models) ice machine electrical	6.5 amps. 7' (2.1 m) cord only.
Utility connection location	internal connection (230 V/50 model includes kit to connect to BSP water fittings)
C3 Water inlet, ice machine	3/8" FPT
C4 Drain, dispenser	3/4" FPT
C5 Water inlet, dispenser	3/8" FPT internal connection – 1.5" (3.81 cm) knockout provided in back or bottom
Ice machine water-cooled connections	
C6 condenser inlet	3/8" FPT
C7 condenser drain	3/8" FPT
C8 Drain, ice machine	3/4" MPT
Air temperature	50 - 100 F (10 - 38 C)
Water temperature	40 - 90 F (4 - 32 C)
Water pressure	10 - 70 psi (69 - 483 kpa)
Ice production at 70 F (21 C) ambient air, 50 F (10 C) inlet water	air-cooled – 454 lb (205.9 kg), water-cooled – 447 lb (202.8 kg)
Ice production at 90 F (32 C) ambient air, 70 F (21 C) inlet water	air-cooled – 323 lb (146.5 kg), water-cooled – 371 lb (168.3 kg)
Energy consumption 90 F (32 C) air, 70 F (21 C) water	air-cooled models – 5.7 kWh, water-cooled models – 5.5 kWh per 100 lb (45.4 kg) ice
Heat rejection	air-cooled models – 5000 BTU/hr, water-cooled models – 1400 BTU/hr to air, 3600 BTU/hr to water
Water flow requirement for water- cooled models	73 gallons/100 lb of ice (276 L/ 45.4 kg)
Water consumption	12.6 gal (47.7 L) of potable water per 100 lb (45.4 kg) of ice
Approximate ship weight	290 lb (131.5 kg)
Approximate ship weight, base stand accessory	140 lb (64 kg)

NOTE: For indoor use only

SHORT FORM SPECIFICATION: (Choose one) ___ Ice and water or ___ ice-only dispenser to be Follett® automatic load in countertop configuration, with 90 lb (40.8 kg) of storage. Environmentally responsible R404a ice machine to be (choose one) ___ air- or ___ water-cooled and to be removable for cleaning and maintenance. Dispenser frame and cabinet to be stainless steel with plastic trim. Ice machine to produce approximately 400 lb (181.4 kg) of Chewblet compressed nugget ice at air temp. of 70 F (21 C), water temp. of 50 F (10 C). Ice machine to be equipped with printed circuit board and diagnostics to allow simplified servicing. Storage area to be insulated with non-CFC, high density, foamed-in-place polyurethane. 7' (2.1 m) cord and NEMA 5-20 90° hospital-grade plug provided (220 V/230 V models, cord only). 115 V, 220 V and 230 V dispensers NSF listed. 115 V dispensers UL and cUL listed. 230 V CE listed.

Dimensional drawing

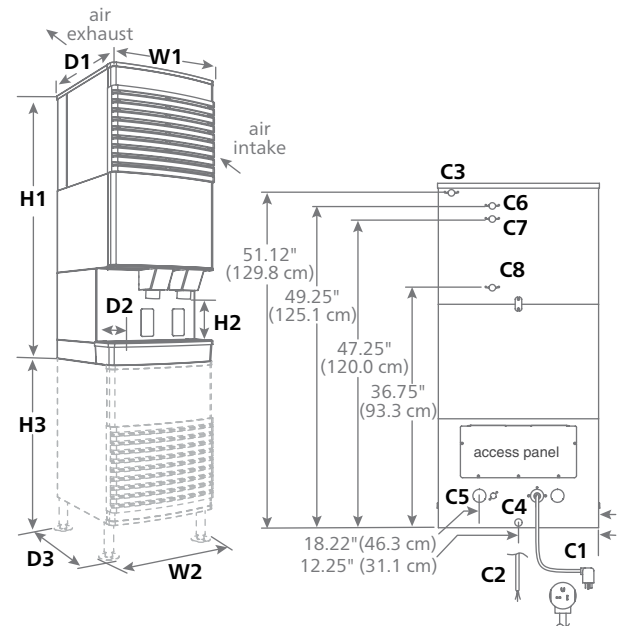

See dispenser detail sheet, form# 2075, for counter cut outs.

- 1 Independent third party studies. Contact Follett for details.
- 2 Disclaimer: Antimicrobial protection is limited to the treated components and does not treat water or ice.

Agion is a registered trademark of Sciessent LLC.

Calgon is a licensed tradename distributed by Nu-Calgon, in the United States.

Symphony, SensorSAFE and SafeCLEAN are trademarks of Follett Corporation.

Chewblet and Follett are registered trademarks of Follett Corporation, registered in the US.

Follett reserves the right to change specifications at any time without obligation. Certifications may vary depending on country of origin.

110 CT series countertop

Form #2090 04/14
© 2013 Follett Corporation



Follett Europe Polska Sp. z o.o.
Mokry Dwór 26C 83-021 Wiślnia, Poland
+48 (58) 785-6140 | Fax: +48 (58) 785-6159
folletteurope.com

801 Church Lane | Easton, PA 18040, USA
1.610.252.7301 | Fax: +1.610.250.0696 | follette.com

FOLLETT
Innovative solutions, inspired by ice