

**HOBART**701 S Ridge Avenue, Troy, OH 45374  
1-888-4HOBART • www.hobartcorp.com**1HG35M  
GAS FRYER****HOBART****STANDARD FEATURES**

- Stainless steel fry tank, 35 - 40 lb. capacity, includes limited 10 year tank warranty
- 1" full port ball type drain valve
- Stainless steel front, top, sides and door
- Set of four casters (two locking)
- 90,000 BTU/hr. input
- Behind the door millivolt thermostat control adjusts from 200°F to 400°F
- Three heat exchanger tubes positioned for easy cleaning
- High limit control
- Combination gas shut-off valve, pressure regulator and pilot ignition system
- Tank brush, stainless steel crumb scoop and clean-out rod

**MODEL**

- **1HG35M:** Behind the door millivolt thermostat control adjusts from 200° to 400°F.

Specifications, Details and Dimensions on Reverse Side.

**ACCESSORIES**

- HGRO15 add-on frymate
- Stainless steel tank cover
- Grease protector strips
- Elevation Kit for altitudes above 3,000 ft.
- Set of 6½" stainless steel legs
- Flexible gas hose with quick disconnect and restraining device.

**1HG35M GAS FRYER**

# 1HG35M GAS FRYER



701 S Ridge Avenue, Troy, OH 45374  
1-888-4HOBART • www.hobartcorp.com

## SPECIFICATIONS

### CONSTRUCTION:

35 - 40 lb. capacity floor model gas fryer. Stainless steel front, top, sides and door. Stainless steel fry tank with three heat exchanger tubes and a "V" shaped cold zone. Set of four casters (two locking), 1" full port ball type drain valve. Twin fry baskets with plastic coated handles.

### TANK SIZE:

14" x 14".

### HEATING:

90,000 BTU/hr. input.

### WORKING HEIGHT:

36 $\frac{1}{4}$ ".

### APPROXIMATE SHIPPING WEIGHT:

200 lbs.

## DETAILS AND DIMENSIONS

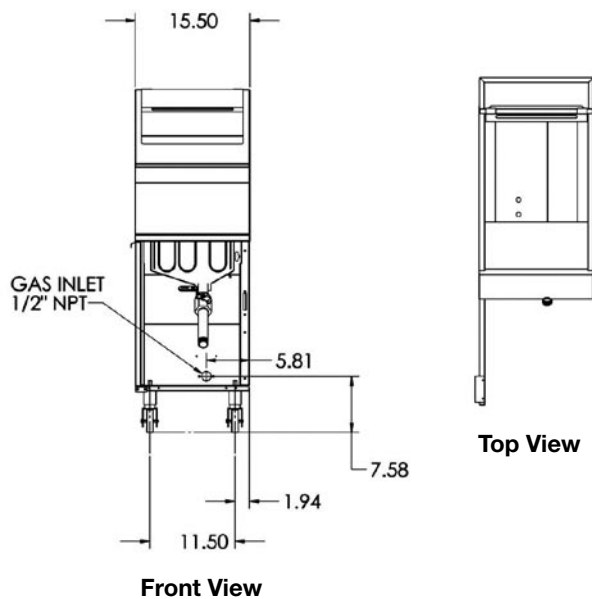

### IMPORTANT

1. A combination valve with pressure regulator is provided with this unit.  
Natural Gas 4.0" W.C.  
Propane Gas 10.0" W.C.
2. An adequate ventilation system is required for Commercial Cooking Equipment. Information may be obtained by writing to the National Fire Protection Association, Batterymarch Park, Quincy, MA 02269. When writing refer to NFPA No. 96.
3. All models require a 6" clearance at both sides and rear adjacent to combustible construction.
4. All models require a 16" minimum clearance to adjacent open top burner units.
5. This appliance is manufactured for commercial installation only and is not intended for home use.

### SERVICE CONNECTIONS:

- (P1)  $\frac{1}{2}$ " rear gas connection (single units).

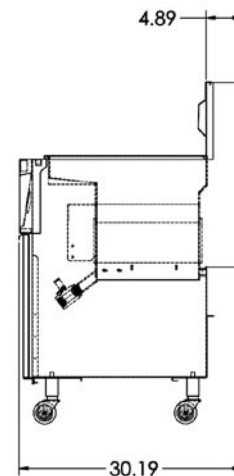
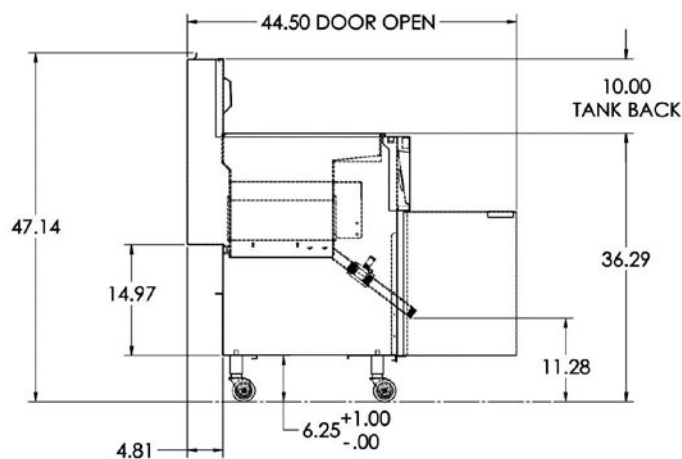

Side Views

MODEL	WIDTH	DEPTH	OVERALL HEIGHT	WORKING HEIGHT	TANK SIZE	BTU/HR.	FRY COMP. CAPACITY	NO. OF CHICKEN PIECES*	APPROX. SHIP. WT.
1HG35M	15 $\frac{1}{2}$ "	30 $\frac{1}{4}$ "	47 $\frac{1}{8}$ "	36 $\frac{1}{4}$ "	14" x 14"	90,000	35 - 40 lbs.	24	200 lbs.

\*Based on 5 birds cut into 8 pieces

As continued product improvement is a policy of Hobart, specifications are subject to change without notice.