

HOBART701 S Ridge Avenue, Troy, OH 45374
1-888-4HOBART • www.hobartcorp.com**CE20FD BOILERLESS
FULL SIZE COMBI OVEN****HOBART****STANDARD FEATURES**

- Multiple cooking modes in one piece of equipment: Convection, Steam and Combination modes achieve Baking, Grill/Roasting, Steaming, Proofing, Rethermalization, Low Temp, Healthy-Fry™, Delta-T, Finishing, Poaching, Stewing, and Defrosting results.
- Electric boilerless combi which uses a direct steam creation method.
- Humidity control from 0-100% of possible maximum relative humidity at chosen temperature.
- Manual operation or programmable up to 100 recipes with 10 cooking phases each.
- Standard with trolley insert and (10) racks.
- Core probe supplied as standard.
- 4-speed auto reversing fan with electrical braking system on fan motor.
- Rack ID multi-shelf timers allow up to 10 different time settings for your cooking environment.
- Halogen lights (4) built into door behind heat reflective glass.
- Flashing door lights & audible alarm system alert user when cooking cycle finished.
- Includes Bluetooth® communication and recipe software for PC.
- Automatic cleaning programs with auto cool down and auto dosing detergent pump featuring hands-free use of built-in wash arm operating with non-proprietary cleaning detergent. Programmable for automatic daily cleaning at user chosen time and cleaning strength without operator involvement.
- Advanced diagnostic with fault history indication, water cooled independent control boards, with LED indicators for service efficiency.
- Cool to the touch & energy efficient heat reflective panoramic curved exterior glass door and insulated panels reflect heat back into the oven.
- Optimized cooking functions for maximum production with minimal energy and water consumption.
- Two (2) year parts warranty on control boards, one (1) year parts and labor warranty standard.
- Combi is compatible with Traulsen hot and cold products.

ACCESSORIES

- ADDRACK-F – Additional wire rack - full size (standard with ten)
- RACK-HANGRH – Rack hanger for holding wire racks
- 1220-BASKET – Fry basket - 12" x 20"
- GRILL-ROD – Grilling grid (rod) - 12" x 20"
- GRILL-SQUARE – Grilling grid (square) - 12" x 20"

MODEL

- **CE20FD** – Electric Boilerless Full Size Combi Oven

ACCESSORIES (Continued)

- CHICKRK-TEN – Chicken rack - Holds up to (10) 3 lb. birds per rack
 - SCAN-1 – Wireless Bluetooth® barcode scanner
 - HCPC-1 – Wireless communication package with HACCP monitoring and recording
 - TTI-20F – Removable trolley for 20F (extra)
 - BTI-20F – Removable banqueting trolley for 20F
 - THERMAL-20F – Thermal cover for 20F trolley
 - Water Filtration Minimum Recommendation for Warranty Purposes:
 - CB15K-SYSTEM – 15,000 gal.
 - CB30K-SYSTEM – 30,000 gal.
 - WS55E-COMBI – water treatment bundled package
 - 2nd year parts and labor warranty – 20F Combi (standard with WS55E-COMBI)
 - Consult factory for additional accessories/options
- Specifications, Details and Dimensions on Back.



CE20FD
shown with standard TTI-20F

CE20FD BOILERLESS FULL SIZE COMBI OVEN

CE20FD BOILERLESS FULL SIZE COMBI OVEN



701 S Ridge Avenue, Troy, OH 45374
1-888-4HOBART • www.hobartcorp.com

SPECIFICATIONS:

General: Hobart Combi Oven, Electric, Boilerless, 20 level full size combi.

Construction: All stainless steel interior and exterior, top, rear, sides, and bottom are fully insulated. All welded stainless steel cooking compartment. Stainless steel oven door features a large curved outer glass with enhanced insulation for a cool to touch exterior, with full length hinged floating inner glass panel. A full perimeter door gasket with drip tray inside door and oven frame. Door opens right to left and swings a full 180 degrees. Standard with trolley insert, preheat bridge and (10) wire racks. Built in wash arm for automatic cleaning with auto dosing pump, 4-speed auto reversing fan, (4) halogen flashing door lights, core probe, dual point door latch connection for a full perimeter sealed connection. Standard with 7.6" adjustable feet.

Controls: Simple, user friendly digital controls on the right with large indicative low voltage LCD display - for easy cleaning and operating pleasure. Manual operation or programmable up to 100 recipes with 10 cooking phases each. Includes Bluetooth® communication and recipe software for PC.

Operation: Electric boilerless combi which uses a direct steam creation method. Hobart's Boilerless Combi uses optimized cooking functions for maximum production with minimal energy and water consumption.

Water: A suitable Hobart Water Treatment System is the recommended minimum to meet the water quality spec. ¾" NSHT cold water, 30-60 psi and 1" NPT drain connection.

Capacity: Capable of holding: (40) 12" x 20" x 2½" steam table pans or (20) 18" x 26" sheet pans or (40) 13" x 18" x 1".

DETAILS AND DIMENSIONS:

Model	Width	Depth	Height	Weight
CE20FD	35.4"	45.8"	70.4"	694 lbs.

LEGEND:

1. ELECTRICAL
2. DRAIN
3. ALTERNATE DRAIN
4. WATER SUPPLY

Clearance: Left 1", Back 2", Right 2" required, 18" recommended for service access.

Note: For trolley use –

- 1) Floor in front of and under combi must be level.
- 2) Must have clearance to open door 140° minimum.

User Responsibility: The product must be installed, cleaned and maintained as described in the Manual furnished with the product.

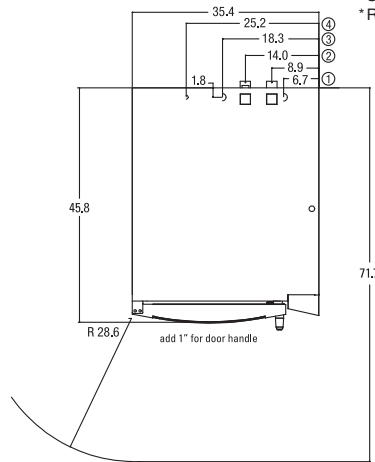

Model	Voltage	Amps (max used)	Watts	Fuse* (amps)
CE20FD-1	208/60/3	103.8	37400	150
CE20FD-3	230-240/60/3	93.8-102.1	37400-40700	150
CE20FD-2	480/60/3	45	37400	60

NOTES:

Amperage values in the table are nominal. Tolerance is +5/-10%. Convection heater currents must be measured in full power convection heat mode. Steam generator heater currents must be measured in full power steam mode. * Recommended size. Always refer to the NEC, state and local codes.

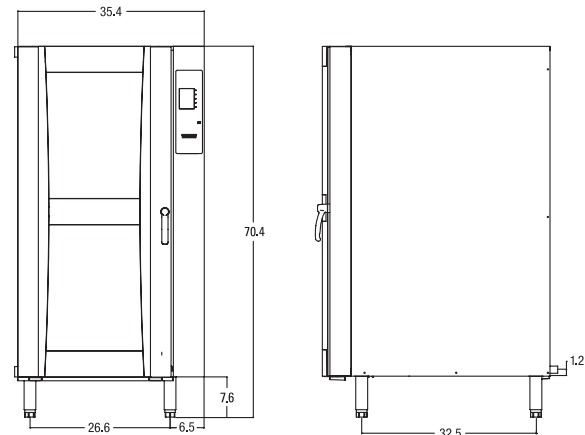

Water Quality Specification for Warranty Purposes

The fact that a water supply is potable is no guarantee that it is suitable for steam generation. All steam equipment is subject to contamination and failure due to chemical and mineral content found in water. A suitable Hobart Water Treatment System and regular filter replacements coupled with routine deliming is the recommended minimum. Damage as a result of poor water quality or lack of required owner/operator maintenance is the responsibility of the owner/operator.

Your water supply must be within these general guidelines:

DYNAMIC WATER PRESSURE	30-60 psig
HARDNESS *	less than 3 grains
SILICA	less than 13 ppm
TOTAL CHLORIDE	less than 30 ppm
Ph RANGE	7-8
CHLORINE & CHLORAMINE	0 ppm
ALKALINITY	Less than 20 ppm
TDS	Less than 60 ppm

UN-DISSOLVED SOLIDS

* 17.1 ppm = 1 grain of hardness

less than 5 microns

Other factors affecting steam generation are iron content, amount of chlorination and dissolved gasses. Water supplies vary from state to state and from locations within a state. Therefore it is necessary that the local water treatment specialist be consulted before the installation of any steam generating equipment.

Note:

- Installation of backflow preventers, vacuum breakers and other specific code requirements is the responsibility of the owner and installer in compliance with local codes.
- Plastic drains are not recommended due to inherent limited temperatures of the plastic. The installer may be required to provide means to reduce water drain temperature to be that of the condensate temperature of 140°F or less.

NOTICE: Fluorescent lamp in display panel contains a small amount of mercury. Please dispose of according to local, state or federal laws.

As continued product improvement is a policy of Hobart, specifications are subject to change without notice.