

HOBART701 S Ridge Avenue, Troy, OH 45374
1-888-4HOBART • www.hobartcorp.com**LXi
DISHMACHINE****HOBART****STANDARD FEATURES**

- 30 racks per hour
- .74 gallons of water per rack
- Hot water or chemical sanitation units available
- Low chemical alert indicator (on machines ordered with pumps, standard on chemical machine)
- Sense-A-Temp™ booster heater capable of 70° rise, provided on LXiH models
- Delime notification with cycle
- Chemical pump “auto-prime”
- Service diagnostics
- 16 gauge stainless steel tank
- Microcomputer, top mounted controls with digital cycle/temperature display
- Revolving upper and lower anti-clogging wash arms
- Revolving upper and lower rinse arms
- Removable stainless steel scrap screen
- Corrosion resistant pump
- Automatic pumped drain
- 17" door opening
- Automatic fill
- Labyrinth-type door seal
- Electric tank heat
- Two dishracks – one peg and one combination-type

STANDARD VOLTAGES

- 120/60/1 (LXiC model only)
- 120/208-240(3W)/60/1

OPTIONS AT EXTRA COST

- 208-240(2W)/60/1
- Detergent and rinse aid pumps

ACCESSORIES

- Power cord kits
- Stainless steel base with 6" legs
- 17" stainless steel stand
- Pressure regulator valve
- Trim kit, top cover
- Rolled top, dish rack holder
- DWT1 drain water tempering kit

Specifications, Details and Dimensions on Inside and Back.

**LXi DISHMACHINE**

LXi DISHMACHINE



701 S Ridge Avenue, Troy, OH 45374
1-888-4HOBART • www.hobartcorp.com

WARNING:

REQUIRED FLOWING WATER PRESSURE TO THE DISHMACHINE IS 20 ± 5 PSIG. IF PRESSURES HIGHER THAN 25 PSIG ARE PRESENT, A PRESSURE REGULATING VALVE MUST BE INSTALLED IN THE WATER LINE TO THE DISHMACHINE (BY OTHERS).

IMPORTANT: THE SODIUM HYPOCHLORITE (LIQUID BLEACH) CONTAINER SHOULD BE PLACED NO HIGHER THAN 10" ABOVE FLOOR.

IF BLEACH CONTAINER IS TO BE PLACED IN CABINET ADJACENT TO MACHINE, A 1/2" DIA. HOLE IS REQUIRED IN THE CABINET TO RUN BLEACH SUPPLY LINE.

USE ONLY 6% SODIUM HYPOCHLORITE (LIQUID BLEACH) AS SANITIZING CHEMICAL TO INSURE PROPER OPERATION OF DISHMACHINE. IF 8.4% IS TO BE UTILIZED CONTACT HOBART SERVICE TO CHANGE THE SANITIZER PUMP SETTINGS.

DO NOT PRE-MIX RINSE AGENT AND SODIUM HYPOCHLORITE (LIQUID BLEACH).

CERTAIN MATERIALS INCLUDING SILVER PLATE, ALUMINUM AND PEWTER ARE ATTACKED BY SODIUM HYPOCHLORITE (LIQUID BLEACH). SEE INSTRUCTIONAL MANUAL.

STEAM GENERATED FROM NORMAL OPERATION MAY ESCAPE FROM THE DOOR. WOOD LAMINATE, VENEERS, ETC. ARE UNSUITABLE MATERIALS FOR USE IN AREAS EXPOSED TO DISHWASHER STEAM AND DETERGENTS. STAINLESS STEEL OR OTHER MOISTURE-RESISTANT SHIELDS ARE RECOMMENDED FOR SURFACES ADJACENT TO LXI SIDES AND TOP.

NOTES:

1. ALL VERTICAL MACHINE DIMENSIONS TAKEN FROM FLOOR MAY BE INCREASED BY 1".
2. MOIST AIR ESCAPES FROM THE DOOR. USE ONLY MOISTURE RESISTANT MATERIALS ADJACENT TO LXI SIDES AND TOP.
3. A VENT HOOD IS NOT RECOMMENDED ABOVE THE LXI UNDERCOUNTER DISHWASHER SINCE IT DOES NOT PRODUCE EXCESSIVE VAPORS

PLUMBING NOTES:

1. WATER HAMMER ARRESTOR (MEETING ASSE-1010 STANDARD OR EQUIVALENT) TO BE SUPPLIED (BY OTHERS) IN COMMON WATER SUPPLY LINE AT SERVICE CONNECTION.
2. RECOMMENDED WATER HARDNESS TO BE 4-6 GRAINS FOR BEST RESULTS.
3. MINIMUM WATER CONDUCTIVITY REQUIRED - 30 MICROMHOS/CM.

⚠ IF DRAIN HOSE IS LOOPED ABOVE A SINK, THE LOOP MUST NOT EXCEED 38" AFF.

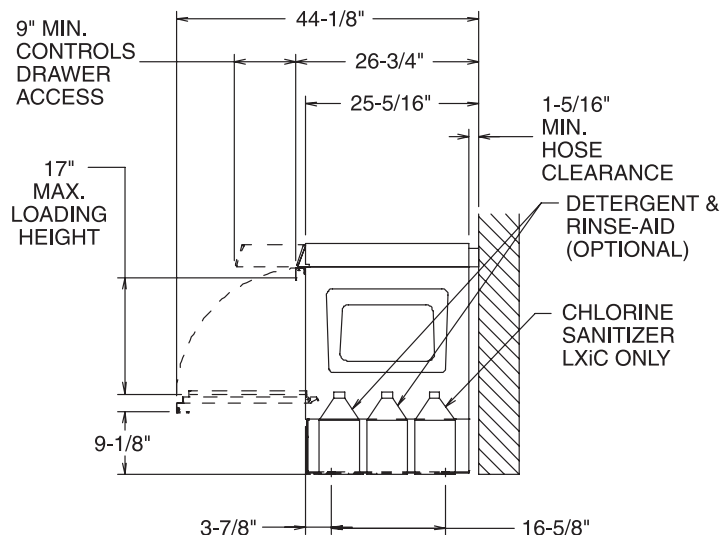
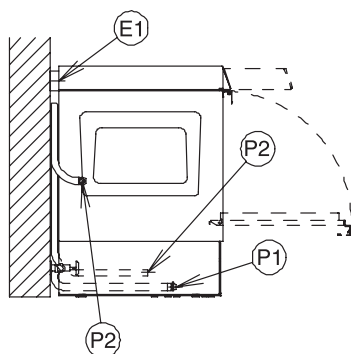

MACHINE TYPE & SPECIFICATION	RATED AMPS	MIN SUPPLY CKT CONDUCT AMPACITY	MAX PROTECTIVE DEVICES
LXiC (120/60/1) USE 90°C STRANDED COPPER WIRE ONLY.	15.4	20	20
LXiC (120/208-240(3W)/60/1*) LXiC (208-240/60/1) USE 90°C STRANDED COPPER WIRE ONLY.	13.6	20	20
LXiH (120/208-240(3W)/60/1*) LXiH (208-240/60/1) USE 90°C STRANDED COPPER WIRE ONLY.	37.7	50	50
ELECTRICAL OPTIONS BELOW ARE NON STANDARD VOLTAGES AVAILABLE AT EXTRA COST. CONSULT FACTORY FOR PRICING AND LEAD TIME.			
LXiH 208-240/60/3	29.5	35	35
480/60/3	14.8	20	20
220-240/50/1	38.1	50	50
380-400/60/3	17.1	25	25

**CONNECTION INFORMATION
(AFF = ABOVE FINISHED FLOOR)**

LEGEND

- E1 ELECTRICAL CONNECTION: 1-3/8" DIA. HOLE FOR 1" TRADE SIZE CONDUIT; 31-3/4" AFF.
- P1 SINGLE FILL AND RINSE CONNECTION: 3/4" FEMALE GARDEN HOSE FITTING ON 6' LONG HOSE SUPPLIED WITH MACHINE; 140°F WATER MIN. FOR LXiC, 110°F WATER MIN. FOR LXiH, 1-1/2" AFF.
- P2 DRAIN CONNECTION: 3/4" MPT FITTING WITH 6' LONG HOSE SUPPLIED WITH MACHINE; 3-9/16" AFF.



701 S Ridge Avenue, Troy, OH 45374
1-888-4HOBART • www.hobartcorp.com

LXi DISHMACHINE

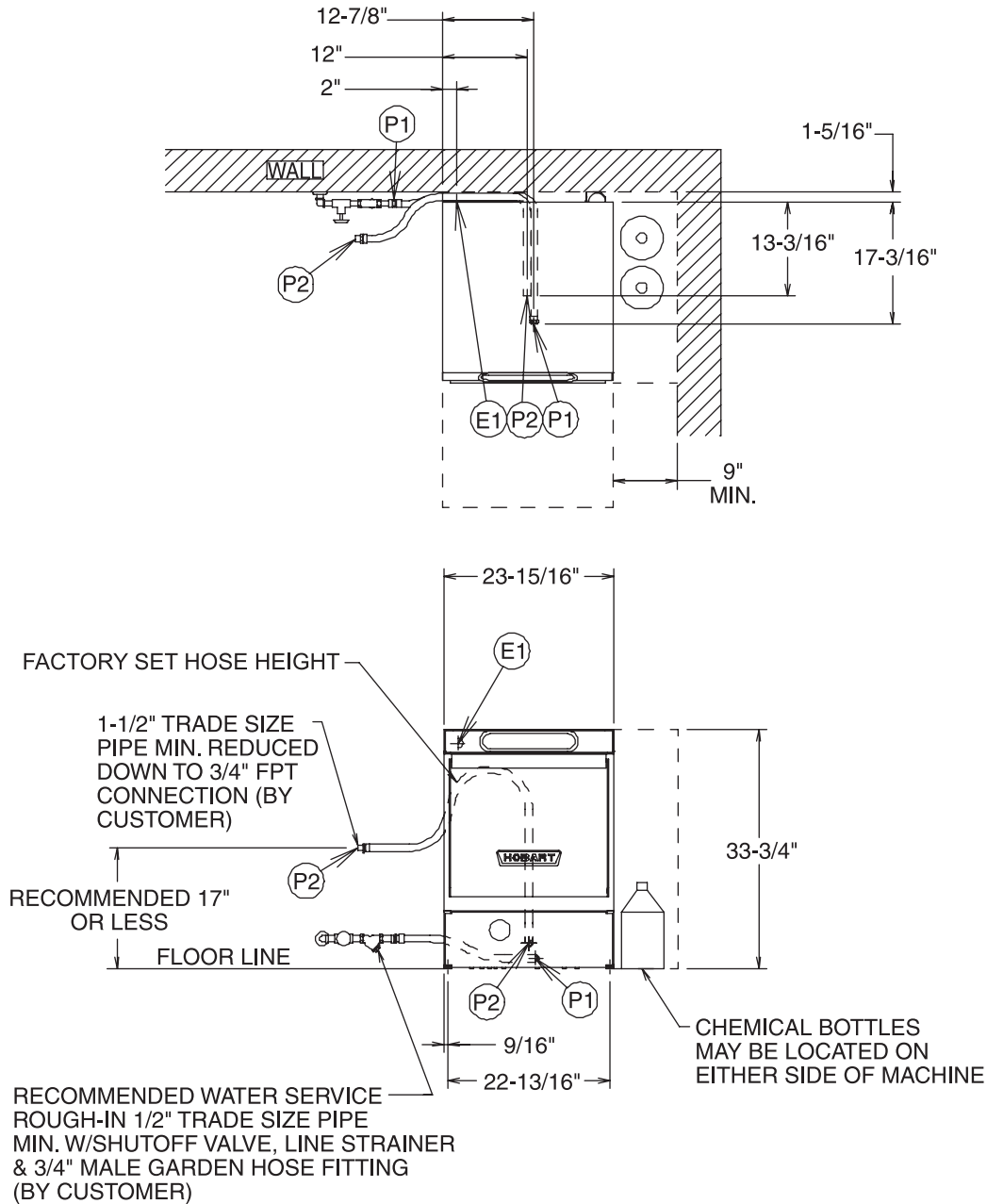

* THIS SYSTEM REQUIRES THREE POWER WIRES WHICH INCLUDES A CURRENT CARRYING NEUTRAL, AN ADDITIONAL FOURTH WIRE MUST BE PROVIDED FOR MACHINE GROUND.

ACCESSORY CORD KITS AVAILABLE FOR ALL MACHINES

WARNING

ELECTRICAL AND GROUNDING CONNECTIONS MUST COMPLY WITH THE APPLICABLE PORTIONS OF THE NATIONAL ELECTRICAL CODE AND/OR OTHER LOCAL ELECTRICAL CODES.

PLUMBING CONNECTIONS MUST COMPLY WITH APPLICABLE SANITARY, SAFETY AND PLUMBING CODES. DRAIN AND FILL LINE CONFIGURATIONS VARY, SOME METHODS ARE SHOWN ON THIS DRAWING.

SHIPPING WEIGHTS (LBS)	LXiC	LXiH
NET WEIGHT OF MACHINE	190 lbs.	210 lbs.
DOMESTIC SHIPPING WEIGHT	235 lbs.	255 lbs.

MODELS:
LXiC, LXiH
892882

LXi DISHMACHINE



701 S Ridge Avenue, Troy, OH 45374
1-888-4HOBART • www.hobartcorp.com

SPECIFICATIONS

DESIGN: Front opening, equipped for installation of both freestanding and undercounter-type operations.

CONSTRUCTION: 304 series stainless steel tank, door and top panel.

PUMP: Centrifugal-type, integral with motor, horizontally mounted. Pump capacity 54 gpm.

MOTOR: Single phase, split-phase type, furnished for 120/60/1 or 208-240/60/1 electrical specification. Factory sealed lubrication. Inherent overload protection with auto reset. Also available with three phase motors at extra cost.

WASH AND RINSE CYCLE: Complete automatic type, controlled by solid-state electronics. Cycle may be interrupted any time by opening door. Cycle continues when door is closed.

- Initial cycle fills wash tank, to be recirculated each wash cycle. Some wash water is drained off before rinse cycle. Rinse cycle refreshes wash water and tank heat.

RINSE AND SANITATION:

- **LXiH:** Sanitation is accomplished by means of a built-in booster heater designed to raise temperature of water to a minimum of 180°F from an incoming water temperature of 110°F.
- **LXiC:** Sanitation is accomplished by injection of proper amount of sodium hypochlorite solution (liquid bleach) into final rinse water to achieve a minimum of 50PPM sanitizing solution. Injection of sodium hypochlorite is accomplished by a built-in sanitizing chemical pump.

PUMPED DRAIN: Machine automatically drains water through a built-in pump. Maximum 38" drain height permitted.

RACKING: Machines accommodate racks from 10" x 20" to 20" x 20". Also accepts 16" x 18" cafeteria trays.

CAUTION: Certain materials, including silver, aluminum and pewter are attacked by Sodium Hypochlorite solution in the chemical sanitizing mode of operation.

SPECIFICATIONS: Listed by Underwriters Laboratories Inc. and NSF International.

MACHINE RATINGS	LXiC	LXiH
Racks per Hour Rate	30	
Dishes per Hour (25 per Rack Avg.)	750	
Glasses per Hour (36 per Rack Avg.)	1080	
Controls	Microcomputer	
Tank Capacity - Gallons	3	
Overall Dimensions - H x W x D	33 ³ / ₄ " x 23 ¹⁵ / ₁₆ " x 26 ³ / ₄ "	
Cycle Time - Minutes	2	
Tank Heat	1.5 KW	
Electric Booster Heater	N/A	6 KW
Water Usage Per Rack - Gallons	.74	
Drain Design	Pumped	
Door Opening Height	17"	
Chemical Connection Capability	Standard	
Detergent Pump	Optional	
Rinse-Aid Pump	Optional (W/Det Pump)	
Sanitizer Pump	Standard	N/A
Chemical Prime (auto prime)	Standard	
Peak Drain Flow - GPM	4	
Service Diagnostics	Standard	
70° Rise Sense-A-Temp™ Booster Heater	N/A	Standard

As continued product improvement is a policy of Hobart, specifications are subject to change without notice.