



701 S Ridge Avenue, Troy, OH 45374  
1-888-4HOBART • www.hobartcorp.com

## UW50 UTENSIL/PAN WASHER



### STANDARD FEATURES

- 2.1 gallons of water per rack (booster equipped models)
- 19 racks per hour
- Timed wash cycles for 2, 4 or 6 minutes
- Stainless steel tank, tank shelf, chamber, trim panels, frame and feet
- Solid state heat controls
- Front loading, split-door configuration
- Flat-bottomed, stainless steel frame rack, with one flat grid rack and two tray support racks
- Chamber accepts 16 full-sized sheet pans, or 140-quart mixing bowl
- Two upper and two lower revolving, debossed non-clogging stainless steel wash arms
- Two upper and lower revolving stainless steel rinse arms
- Heavy-duty door and door hinges
- Large, removable stainless steel scrap screen and scrap bucket
- Choice of 10 KW electric, steam injector/steam coil or gas tank heat
- Adjustable wash cycle timer
- Stainless steel front panel
- Integrated detergent connections
- Top-mounted dial thermometers
- Door actuated drain closer
- Heavy-duty 5 H.P. motor
- Door interlock switch
- Corrosion-resistant impeller
- Timed fill
- Positive low water protection
- Spray hose (standard on electric booster heater equipped models only)

### VOLTAGE

- 208/60/3
- 240/60/3
- 480/60/3

### MODEL

- UW50

### OPTIONS AT EXTRA COST

- 10 KW electric tank heat
- Natural or LP gas tank heat
- 14 KW electric booster heater
- Vent fan control
- Steam injector or steam coil tank heat

### ACCESSORIES

- Power vent fan kit
- Drain water tempering kit
- Rack insert for 30" trays
- Spray hose assembly (field installed for non-booster equipped machines only)
- Operator training video
- 20" x 20" peg or combination racks

Specifications, Details and Dimensions on Inside and Back.



UW50 UTENSIL/PAN WASHER

# UW50 UTENSIL/PAN WASHER



701 S Ridge Avenue, Troy, OH 45374  
1-888-4HOBART • www.hobartcorp.com

## DETAILS & DIMENSIONS – ELECTRIC

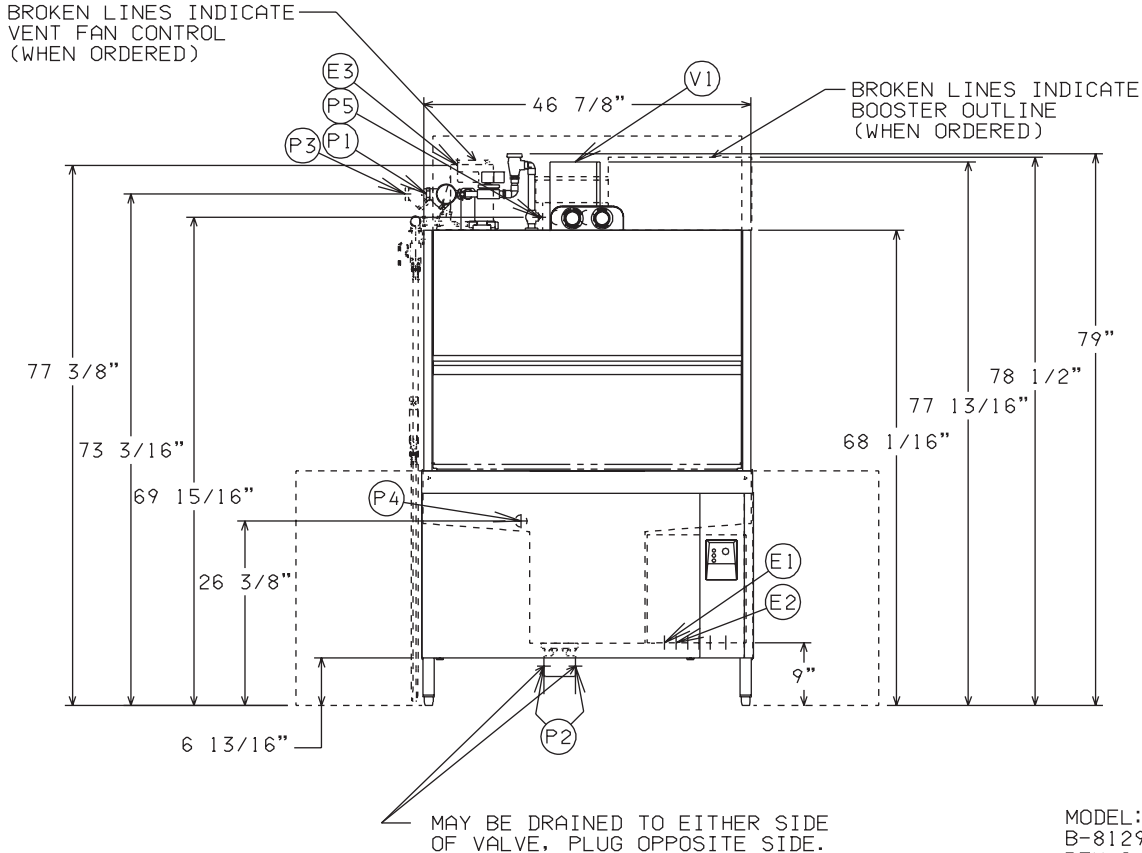

MODEL: UW-50  
B-812969  
REV C  
PER SECTION H

### PLUMBING NOTES:

WATER HAMMER ARRESTOR (MEETING ASSE-1010 STANDARD OR EQUIVALENT) TO BE SUPPLIED (BY OTHERS) IN COMMON WATER SUPPLY LINE AT SERVICE CONNECTION.  
RECOMMENDED WATER HARDNESS TO BE 4-6 GRAINS FOR BEST RESULTS.  
RECOMMENDED BUILDING FLOWING WATER PRESSURE TO THE DISHWASHER IS 20-25 PSI. IF PRESSURES HIGHER THAN 25 PSI ARE PRESENT, A PRESSURE REGULATING VALVE MUST BE SUPPLIED (BY OTHERS) IN THE WATER LINE TO THE DISHWASHER.  
PRESSURE REGULATOR FURNISHED WHEN ELECTRIC BOOSTER IS ORDERED.  
FOR CONVENIENCE WHEN CLEANING, WATER TAP SHOULD BE INSTALLED NEAR MACHINE WITH HEAVY DUTY HOSE AND SQUEEZE VALVE.

### MISCELLANEOUS NOTES:

ALL DIMENSIONS TAKEN FROM FLOOR LINE MAY BE INCREASED BY UP TO 1-1/8" WITH LEG ADJUSTMENT.  
NET WEIGHT OF MACHINE: 640 LBS. W/O BOOSTER  
DOMESTIC SHIPPING WEIGHT: 782 LBS. W/O BOOSTER  
NET WEIGHT OF MACHINE: 704 LBS. W/ BOOSTER  
DOMESTIC SHIPPING WEIGHT: 846 LBS. W/ BOOSTER  
SHIPPING DIMENSIONS:  
60" X 38" X 83" HIGH.  
SIZE OF RACKS:  
40-7/8" X 22-7/8" X 4-1/8"  
DRAIN LEVER LOCATED INSIDE TANK.

### CONNECTION INFORMATION (\*AFF - ABOVE FINISHED FLOOR)

#### LEGEND

- E1 ELECTRICAL CONNECTION (INCLUDING ELECTRIC HEAT) 1-1/4" CONDUIT HOLE, 9" AFF.
- E2 ELECTRICAL CONNECTION-DETERGENT/RINSE AGENT FEEDERS: 1/2" CONDUIT HOLE: 9" AFF
- E3 ELECTRICAL CONNECTION-VENT FAN CONTROL (WHEN ORDERED): 3/4" CONDUIT HOLE: 77-3/8" AFF
- P1 COMMON WATER CONNECTION: 180°F WATER MIN. 3/4" FPT. 73-3/16" AFF.
- P2 DRAIN: 2" FPT. 5-5/8" AFF TWO CONNECTIONS.
- P3 COMMON WATER CONNECTION WITH BOOSTER (WHEN ORDERED): 140°F MIN., 3/4" FPT. 73-3/16" AFF.
- P4 DETERGENT PROBE SENSOR: REMOVE CAP AND STUD ASSEMBLY TO ACCESS 7/8" HOLE, 26-3/8" AFF
- P5 RINSE AGENT FEEDER: 1/8" NPT. REMOVE 1/8" NPT PIPE PLUG TO ACCESS TAPPED HOLE: 69-15/16" AFF.
- V1 VENT EXIT: 7" X 11" X 10" HIGH TO ALLOW FOR EXPANSION OF AIR. (NEED NOT BE CONNECTED TO EXTERNAL VENT); IF REQUIRED, VENT HOOD TO PROVIDE 400 CFM EXHAUST.

SINGLE POINT ELECTRIC CONNECTION UW-50 WITH 10KW ELECTRIC HEAT (CONTROLS AND SHP PUMP MOTOR)			
ELEC. SPECS.	RATED AMPS	MINIMUM SUPPLY CIRCUIT CONDUCTOR CAPACITY	MAXIMUM OVERCURRENT PROTECTIVE DEVICE
208/60/3	50.3	70	70
240/60/3	46.2	60	60
480/60/3	23.5	30	30

SINGLE POINT ELECTRIC CONNECTION UW-50 WITH 10KW ELECTRIC HEAT AND 14KW ELECTRIC BOOSTER (CONTROLS AND SHP PUMP MOTOR)			
ELEC. SPECS.	RATED AMPS	MINIMUM SUPPLY CIRCUIT CONDUCTOR CAPACITY	MAXIMUM OVERCURRENT PROTECTIVE DEVICE
208/60/3	89.2	100	100
240/60/3	79.9	100	100
480/60/3	40.4	50	50

⚠ FOR SUPPLY CONNECTION USE WIRES SUITABLE FOR AT LEAST 90°C OR EQUIVALENT.



701 S Ridge Avenue, Troy, OH 45374  
1-888-4HOBART • www.hobartcorp.com

# UW50 UTENSIL/PAN WASHER

## DETAILS & DIMENSIONS – ELECTRIC

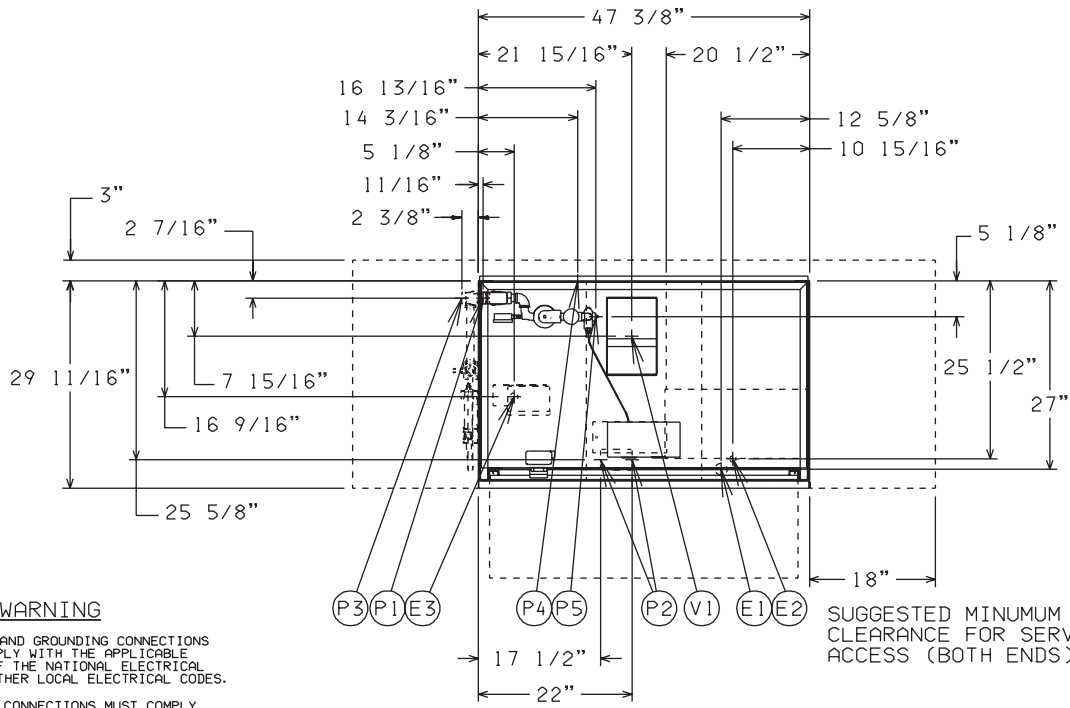
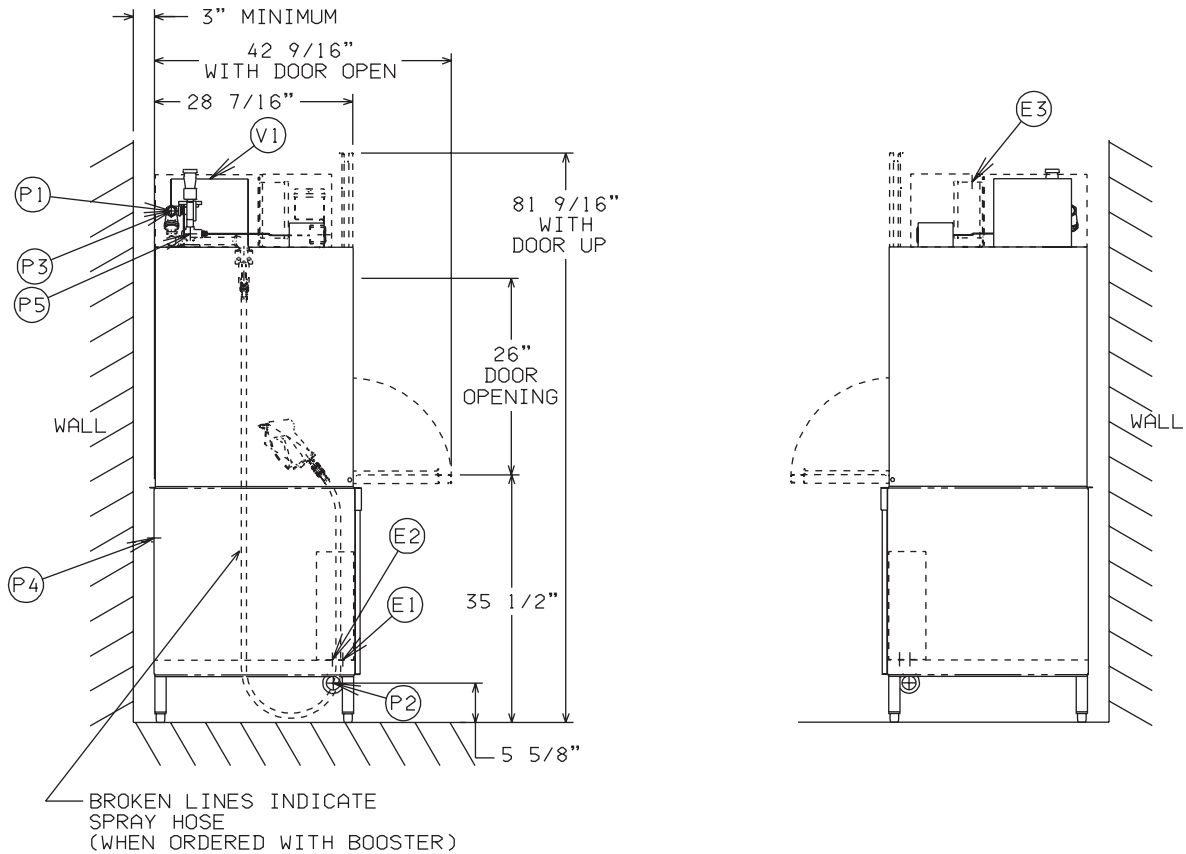

# UW50 UTENSIL/PAN WASHER



701 S Ridge Avenue, Troy, OH 45374  
1-888-4HOBART • www.hobartcorp.com

## DETAILS & DIMENSIONS – GAS

BROKEN LINES INDICATE  
VENT FAN CONTROL  
(WHEN ORDERED)

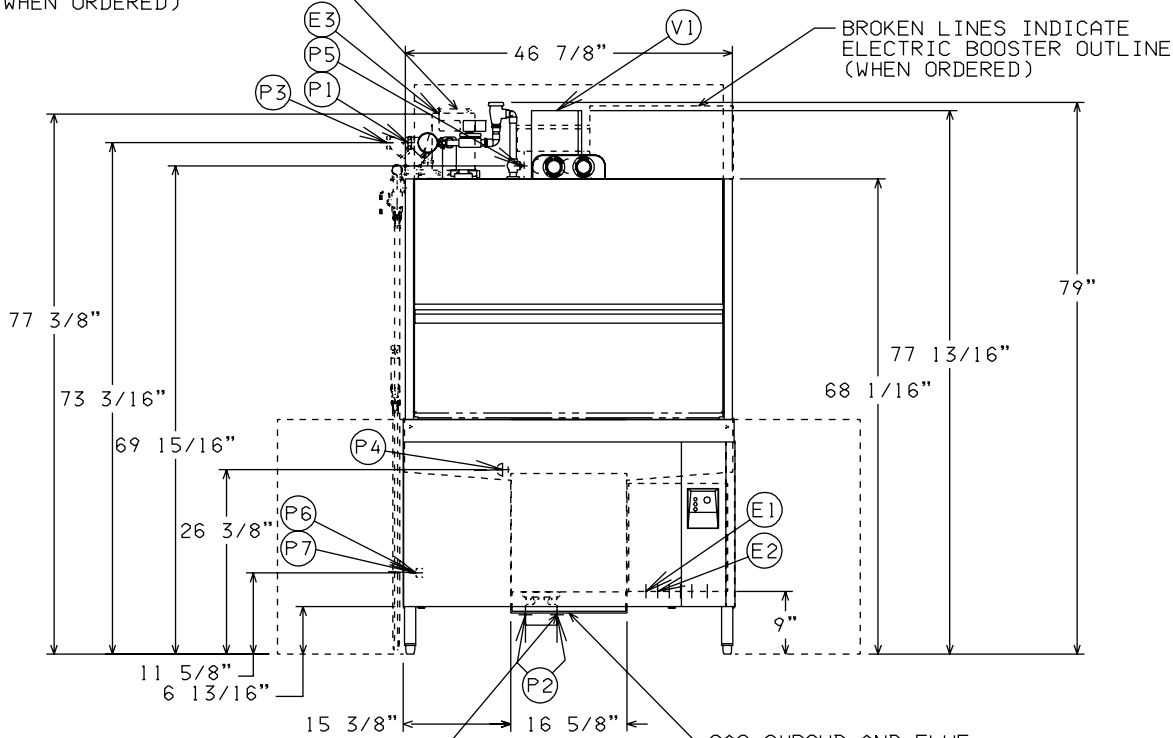

BROKEN LINES INDICATE  
ELECTRIC BOOSTER OUTLINE  
(WHEN ORDERED)

### GAS HEATED DISHWASHERS

FOR NATURAL GAS, PRESSURE TO THE BURNER (CUSTOMER CONNECTION) SHOULD NOT EXCEED 7" W.C.  
FOR LIQUIFIED PETROLEUM GAS, PRESSURE TO THE BURNER (CUSTOMER CONNECTION) SHOULD NOT EXCEED 11" W.C.  
IF GAS PRESSURE IS HIGHER THAN 7" OR 11" W.C., A PRESSURE REGULATING VALVE MUST BE INSTALLED (BY OTHERS) IN THE GAS LINE TO THE DISHWASHER  
GAS HEAT BTU INPUT - 47,000 NATURAL  
47,000 PROPANE

WHEN GAS TANK HEAT IS SPECIFIED, GAS EXHAUST VENTING MUST BE INSTALLED ACCORDING TO LOCAL CODE. DO NOT CONNECT FLUE TO POWER VENT.

### PLUMBING NOTES:

WATER HAMMER ARRESTOR (MEETING ASSE-1010 STANDARD OR EQUIVALENT) TO BE SUPPLIED (BY OTHERS) IN COMMON WATER SUPPLY LINE AT SERVICE CONNECTION.  
RECOMMENDED WATER HARDNESS TO BE 4-6 GRAINS FOR BEST RESULTS.  
RECOMMENDED BUILDING FLOWING WATER PRESSURE TO THE DISHWASHER IS 20-25 PSI. IF PRESSURES HIGHER THAN 25 PSI ARE PRESENT, A PRESSURE REGULATING VALVE MUST BE SUPPLIED (BY OTHERS) IN THE WATER LINE TO THE DISHWASHER.  
PRESSURE REGULATOR FURNISHED WHEN ELECTRIC BOOSTER IS ORDERED.  
FOR CONVENIENCE WHEN CLEANING, WATER TAP SHOULD BE INSTALLED NEAR MACHINE WITH HEAVY DUTY HOSE AND SQUEEZE VALVE.

### MISCELLANEOUS NOTES:

ALL DIMENSIONS TAKEN FROM FLOOR LINE MAY BE INCREASED BY UP TO 1-1/8" WITH LEG ADJUSTMENT.  
NET WEIGHT OF MACHINE: 640 LBS. W/O BOOSTER  
DOMESTIC SHIPPING WEIGHT: 782 LBS. W/O BOOSTER  
NET WEIGHT OF MACHINE: 704 LBS. W/ BOOSTER  
DOMESTIC SHIPPING WEIGHT: 846 LBS. W/ BOOSTER  
SHIPPING DIMENSIONS:  
60" X 38" X 83" HIGH.  
SIZE OF RACKS:  
40-7/8" X 22-7/8" X 4-1/8"  
DRAIN LEVER LOCATED INSIDE TANK.

GAS SHROUD AND FLUE  
THIS AREA MUST BE KEPT CLEAR  
OF ALL PIPING.

MAY BE DRAINED TO EITHER SIDE  
OF VALVE, PLUG OPPOSITE SIDE.

### CONNECTION INFORMATION (\*AFF - ABOVE FINISHED FLOOR)

#### LEGEND

- E1 ELECTRICAL CONNECTION (MOTOR & CONTROLS): 1-1/4" CONDUIT HOLE, 9" AFF.
- E2 ELECTRIC CONNECTION-DETERGENT/RINSE AGENT FEEDERS: 1/2" CONDUIT HOLE: 9" AFF
- E3 ELECTRIC CONNECTION-VENT FAN CONTROL (WHEN ORDERED): 3/4" CONDUIT HOLE: 77-3/8" AFF
- P1 COMMON WATER CONNECTION: 180°F WATER MIN., 3/4" FPT, 73-3/16" AFF.
- P2 DRAIN: 2" FPT, 5-5/8" AFF TWO CONNECTIONS.
- P3 COMMON WATER CONNECTION WITH ELECTRIC BOOSTER (WHEN ORDERED): 140°F MIN., 3/4" FPT, 73-3/16" AFF.
- P4 DETERGENT PROBE SENSOR: REMOVE CAP AND STUD ASSEMBLY TO ACCESS HOLE: 26-3/8" AFF
- P5 RINSE AGENT FEEDER: 1/8" NPT, REMOVE 1/8" NPT PIPE PLUG TO ACCESS TAPPED HOLE: 69-15/16" AFF.
- P6 GAS CONNECTION - NAT.: 1/2" FPT, 11-5/8" AFF.
- P7 GAS CONNECTION - L.P.: 1/2" FPT, 11-5/8" AFF.
- V1 VENT EXIT: 7" X 11" X 10" HIGH TO ALLOW FOR EXPANSION OF AIR. (NEED NOT BE CONNECTED TO EXTERNAL VENT); IF REQUIRED, VENT HOOD TO PROVIDE 400 CFM EXHAUST.

SINGLE POINT ELECTRIC CONNECTION UW-50 WITH GAS HEAT (CONTROLS AND 5HP PUMP MOTOR)			
ELEC. SPECS.	RATED AMPS	MINIMUM SUPPLY CIRCUIT CONDUCTOR AMPACITY	MAXIMUM OVERCURRENT PROTECTIVE DEVICE
208/60/3	21.4	30	30
240/60/3	18.6	25	25
480/60/3	9.6	15	15

SINGLE POINT ELECTRIC CONNECTION UW-50 WITH GAS HEAT AND 14KW ELECTRIC BOOSTER (CONTROLS AND 5HP PUMP MOTOR)			
ELEC. SPECS.	RATED AMPS	MINIMUM SUPPLY CIRCUIT CONDUCTOR AMPACITY	MAXIMUM OVERCURRENT PROTECTIVE DEVICE
208/60/3	60.3	80	80
240/60/3	52.3	70	70
480/60/3	26.4	35	35



701 S Ridge Avenue, Troy, OH 45374  
1-888-4HOBART • www.hobartcorp.com

# UW50 UTENSIL/PAN WASHER

## DETAILS & DIMENSIONS – GAS

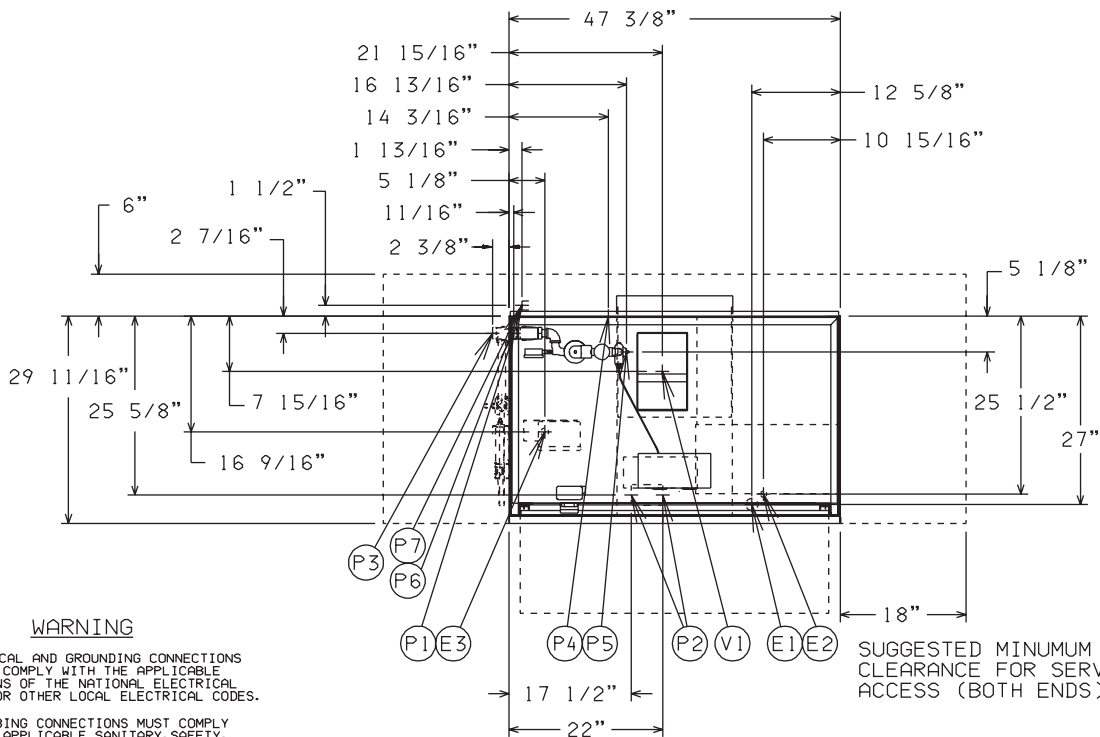
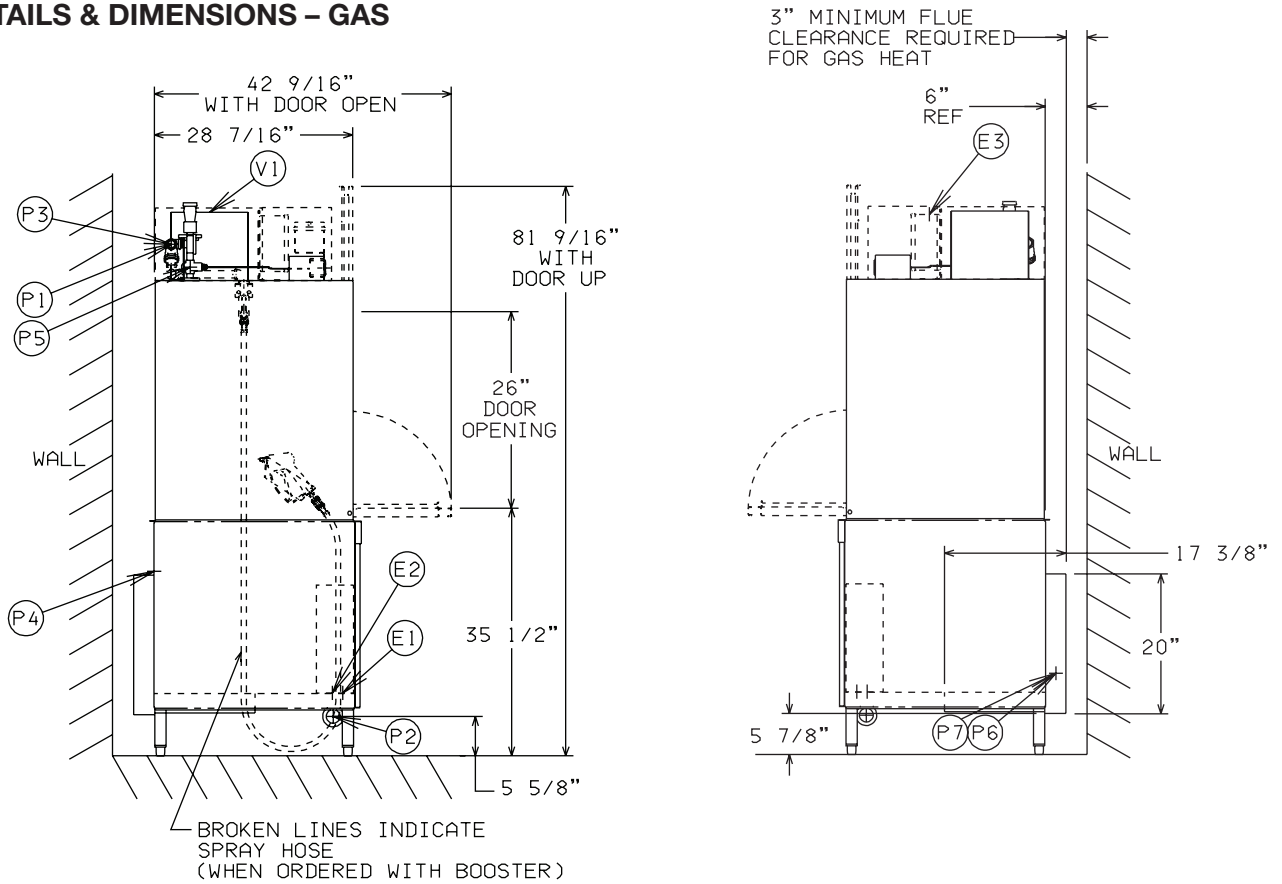

# UW50 UTENSIL/PAN WASHER



701 S Ridge Avenue, Troy, OH 45374  
1-888-4HOBART • www.hobartcorp.com

## DETAILS & DIMENSIONS – STEAM INJECTOR/STEAM COIL

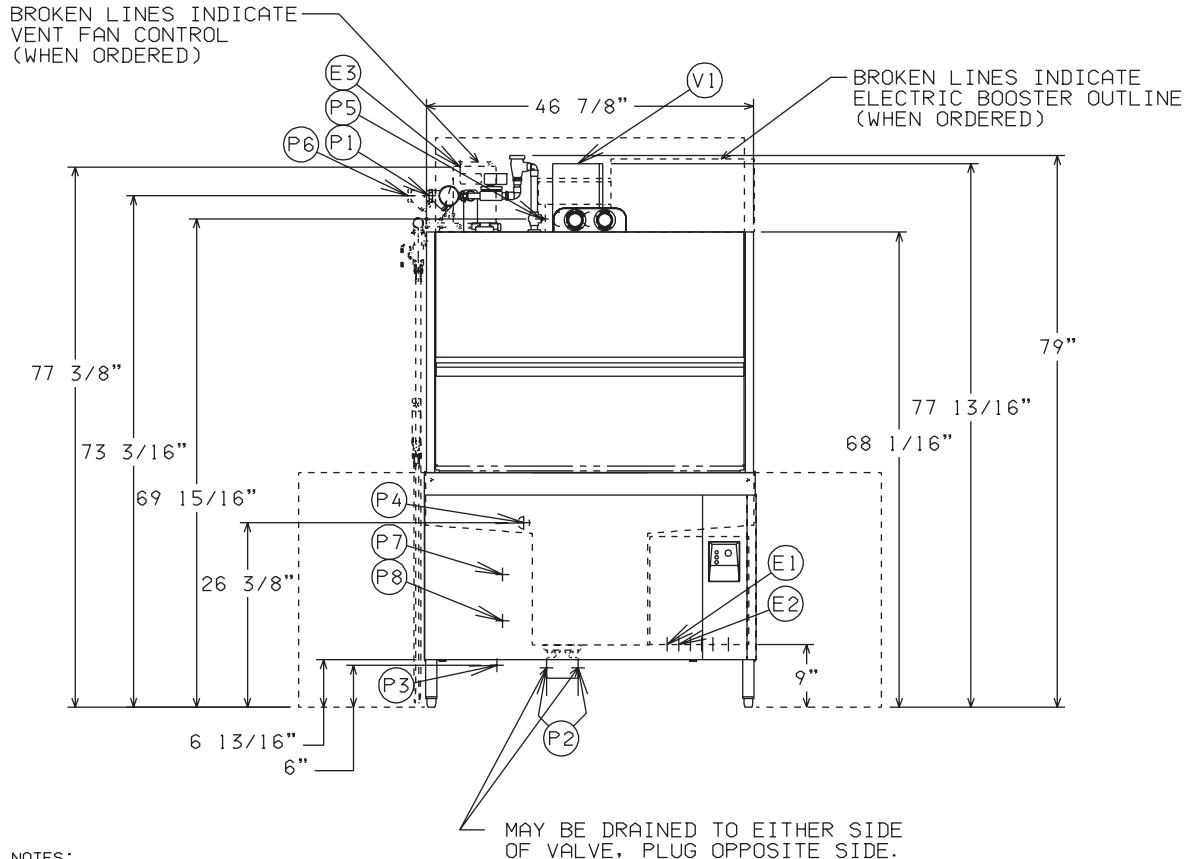

### PLUMBING NOTES:

- WATER HAMMER ARRESTOR (MEETING ASSE-1010 STANDARD OR EQUIVALENT) TO BE SUPPLIED (BY OTHERS) IN COMMON WATER SUPPLY LINE AT SERVICE CONNECTION.
- RECOMMENDED WATER HARDNESS TO BE 4-6 GRAINS FOR BEST RESULTS.
- RECOMMENDED BUILDING FLOWING WATER PRESSURE TO THE DISHWASHER IS 20-25 PSI. IF PRESSURES HIGHER THAN 25 PSI ARE PRESENT, A PRESSURE REGULATING VALVE MUST BE SUPPLIED (BY OTHERS) IN THE WATER LINE TO THE DISHWASHER.
- PRESSURE REGULATOR FURNISHED WHEN ELECTRIC BOOSTER IS ORDERED.
- FOR CONVENIENCE WHEN CLEANING, WATER TAP SHOULD BE INSTALLED NEAR MACHINE WITH HEAVY DUTY HOSE AND SQUEEZE VALVE.
- FLOWING STEAM PRESSURES ABOVE 50 PSI MUST HAVE A PRESSURE REGULATOR (NOT SUPPLIED) INSTALLED IN THE STEAM LINE
- SHUT OFF VALVE MUST BE SUPPLIED (BY OTHERS) IN THE STEAM LINE TO THE DISHWASHER

### MISCELLANEOUS NOTES:

- ALL DIMENSIONS TAKEN FROM FLOOR LINE MAY BE INCREASED BY UP TO 1-1/8" WITH LEG ADJUSTMENT.
- NET WEIGHT OF MACHINE: 640 LBS. W/O BOOSTER  
DOMESTIC SHIPPING WEIGHT: 782 LBS. W/O BOOSTER
- NET WEIGHT OF MACHINE: 704 LBS. W/ BOOSTER  
DOMESTIC SHIPPING WEIGHT: 846 LBS. W/ BOOSTER
- SHIPPING DIMENSIONS:  
60" X 38" X 83" HIGH.
- SIZE OF RACKS:  
40-7/8" X 22-7/8" X 4-1/8"
- DRAIN LEVER LOCATED INSIDE TANK.

### CONNECTION INFORMATION (\*AFF - ABOVE FINISHED FLOOR)

#### LEGEND

- E1 ELECTRICAL CONNECTION (MOTOR & CONTROLS): 1-1/4" CONDUIT HOLE, 9" AFF.
- E2 ELECTRICAL CONNECTION-DETERGENT/RINSE AGENT FEEDERS: 1/2" CONDUIT HOLE; 9" AFF
- E3 ELECTRICAL CONNECTION-VENT FAN CONTROL (WHEN ORDERED): 3/4" CONDUIT HOLE; 77-3/8" AFF
- P1 COMMON WATER CONNECTION: 180°F WATER MIN., 3/4" FPT, 73-3/16" AFF.
- P2 DRAIN: 2" FPT, 5-5/8" AFF TWO CONNECTIONS.
- P3 STEAM INJECTOR: 10 TO 25 PSI FLOWING, 50 PSI MAX.; 3/4" FPT; 6" AFF.
- P4 DETERGENT PROBE SENSOR: REMOVE CAP AND STUD ASSEMBLY TO ACCESS 7/8" HOLE, 26-3/8" AFF
- P5 RINSE AGENT FEEDER: 1/8" NPT, REMOVE 1/8" NPT PIPE PLUG TO ACCESS TAPPED HOLE; 69-15/16" AFF.
- P6 COMMON WATER CONNECTION WITH ELECTRIC BOOSTER (WHEN ORDERED): 140°F MIN., 3/4" FPT, 73-3/16" AFF.
- P7 STEAM COIL : 10 TO 25 PSI FLOWING, 50 PSI MAX., 3/4" FPT, 19" AFF.
- P8 CONDENSATE RETURN: 10 TO 50 PSI FLOWING, 3/4" FPT, 12-3/8" AFF. (BUCKET TYPE TRAP FURNISHED).
- V1 VENT EXIT: 7" X 11" X 10" HIGH TO ALLOW FOR EXPANSION OF AIR. (NEED NOT BE CONNECTED TO EXTERNAL VENT); IF REQUIRED, VENT HOOD TO PROVIDE 400 CFM EXHAUST.

SINGLE POINT ELECTRIC CONNECTION UW-50 WITH STEAM HEAT (CONTROLS AND SHP PUMP MOTOR)			
ELEC. SPECS.	RATED AMPS	MINIMUM SUPPLY CIRCUIT CONDUCTOR CAPACITY	MAXIMUM OVERCURRENT PROTECTIVE DEVICE
208/60/3	20.3	25	25
240/60/3	17.6	25	25
480/60/3	9.2	15	15

SINGLE POINT ELECTRIC CONNECTION UW-50 WITH STEAM HEAT AND 14KW ELECTRIC BOOSTER (CONTROLS AND SHP PUMP MOTOR)			
ELEC. SPECS.	RATED AMPS	MINIMUM SUPPLY CIRCUIT CONDUCTOR CAPACITY	MAXIMUM OVERCURRENT PROTECTIVE DEVICE
208/60/3	60.3	80	80
240/60/3	52.3	70	70
480/60/3	26.4	35	35



701 S Ridge Avenue, Troy, OH 45374  
1-888-4HOBART • www.hobartcorp.com

# UW50 UTENSIL/PAN WASHER

## DETAILS & DIMENSIONS – STEAM INJECTOR/STEAM COIL

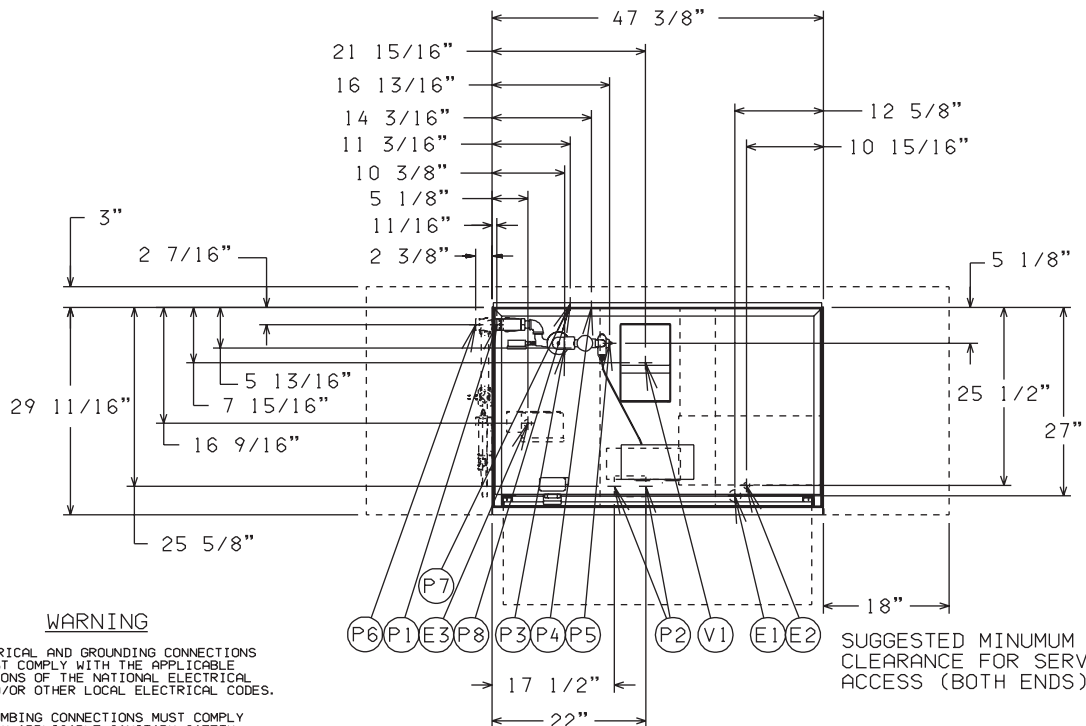
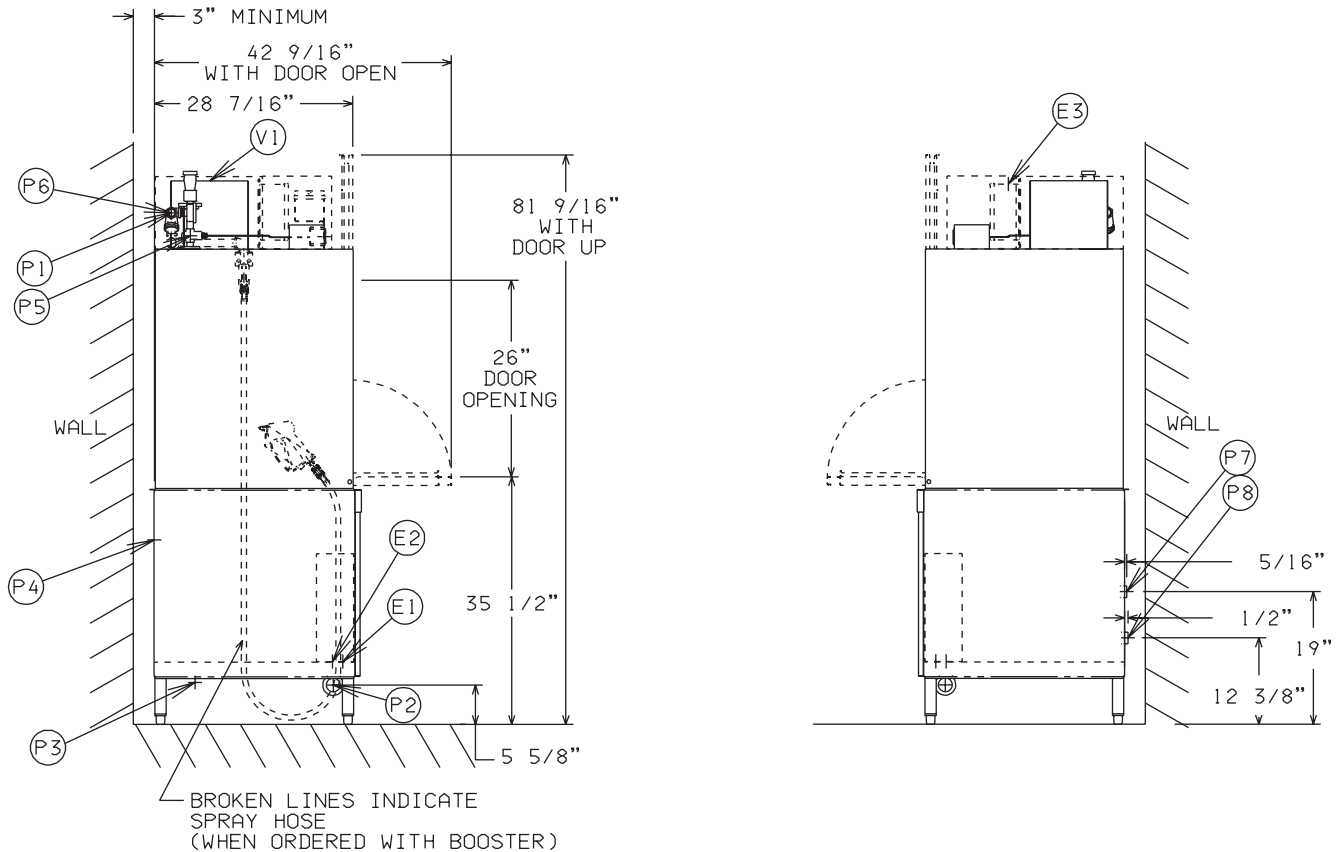

# UW50 UTENSIL/PAN WASHER



701 S Ridge Avenue, Troy, OH 45374  
1-888-4HOBART • www.hobartcorp.com

## SPECIFICATIONS

**DESIGN:** Heavy-duty, fully automatic, front-loading utensil/pan washer with large split door system. Upper door section slides upward as the lower door section is pulled down. Stainless steel pull-out rack allows easy loading for large utensils and pans. Three variable wash cycles ensure thorough cleaning and sanitizing.

**CONSTRUCTION:** Stainless steel tank and hood, frame, legs and adjustable feet. Front enclosure panel standard.

**PUMP:** Cast iron pump integral with motor, Ni-Resist impeller, horizontally mounted. Pump capacity 343 gpm.

**MOTOR:** 5 H.P., available in 208/60/3, 240/60/3, or 480/60/3 configurations. Factory sealed lubrication, drip proof with sealed ball bearings. Thermal overload protection.

### RACKS PER HOUR:

Wash Cycle	Racks/Hr.
2 minute	19
4 minute	12
6 minute	9

**WASH CYCLE:** Complete automatic operation. Cycle may be interrupted any time by opening door. The selected cycle will restart from the beginning when door is closed again.

Upper and lower revolving stainless steel wash arms, with computer designed, debossed, anti-clog wash nozzles, direct high pressure wash flow to all soiled surfaces.

Large, sloping, perforated, removable stainless steel scrap screens direct food soils to a deep perforated stainless steel scrap basket.

Scrap basket and strainer easily removed.

**RINSE CYCLE:** 180°F final sanitizing rinse through two upper and two lower revolving stainless steel rinse arms. Rinse arms removable without tools.

### WATER USAGE PER RACK:

- 2.1 gallons per rack (booster equipped models)
- 2.2 gallons per rack (non-booster equipped models)

**RACKING:** Standard rack assortment consists of one flat-bottomed frame rack, one flat grid insert rack, and two tray support insert racks. External rack dimensions are 40 $\frac{7}{8}$ " wide, 22 $\frac{7}{8}$ " deep, and 4 $\frac{1}{8}$ " high.

Standard flat-bottomed frame rack also accepts (2) 20" x 20" combination or peg racks per cycle.

**SPECIFICATIONS:** Listed by Underwriters Laboratories Inc., NSF International and CUL.

As continued product improvement is a policy of Hobart, specifications are subject to change without notice.