

Electric Countertop Griddle

□TMGE24 □TMGE36 □TMGE48

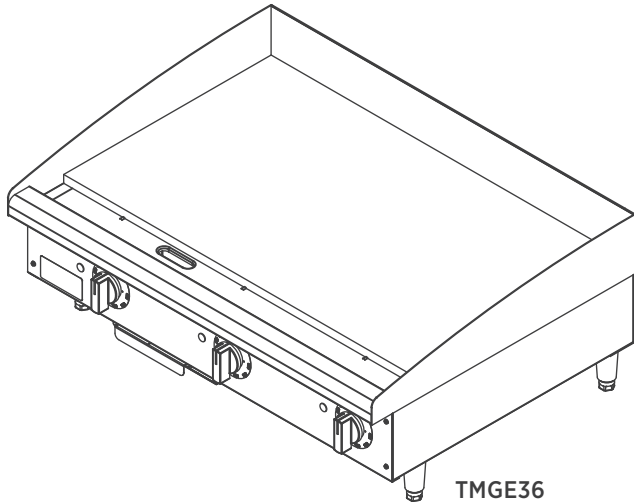

DESCRIPTION

Toastmaster electric griddles are designed to be reliable, efficient, and accurate. Each twelve [12] inch (305 mm) section has its own independent temperature control and the griddle surface is 0.75-inch (19 mm) thick, providing even cooking of a variety of products at the same time.

SPECIFICATIONS

Toastmaster electric countertop griddles will be constructed in the U.S.A. with a corrosion-resistant stainless steel body. The griddle plate will be 0.75-inch (19 mm) thick and will have a polished steel surface. The heating elements will allow control of each twelve [12] inch (305 mm) section and have an independent control for each section. The temperature will be controlled by snap-action thermostats from 150° F (66° C) up to 450° F (232° C). The unit will have one [1] grease drawer. The griddles will be ready to hard-wire to an appropriate electrical connection. Models will operate on 208 V/240 V service. The griddles will be supplied with four [4] inch (102 mm) tall legs that have an adjustment of 1.375 inches (35 mm).

WARRANTY

These units come with a one [1] year warranty for parts and labor.

FEATURES

- 3,000–4,000 watts per twelve inch (305 mm) section of griddle, with individual controls for each section
- Positive-off, snap-action thermostat allows for precise control of temperature from 150° F (66° C) to 450° F (232° C)
- Stainless steel bullnose and front panel.
- 0.75-inch (19 mm) thick polished steel surface
- 3.25-inch wide front grease trough

CERTIFICATIONS



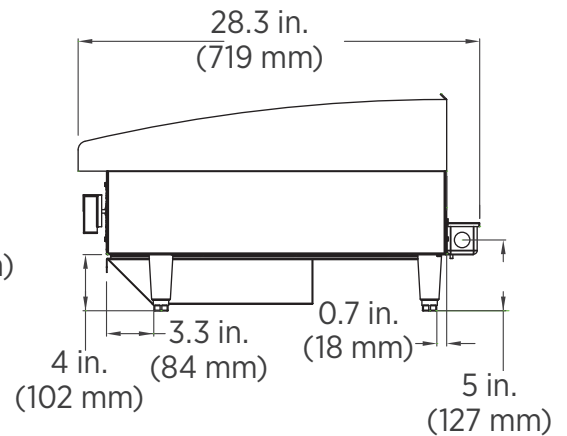
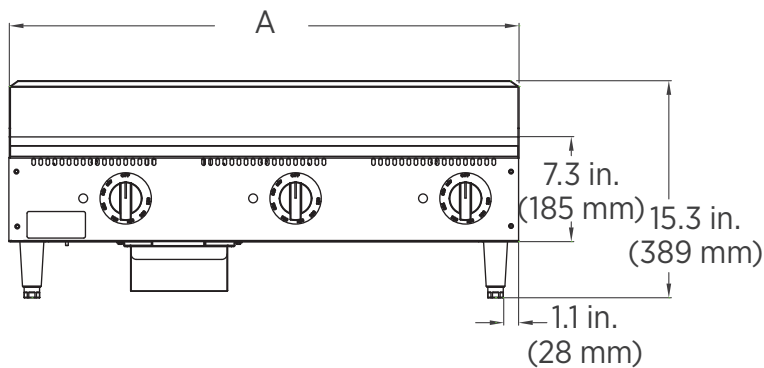
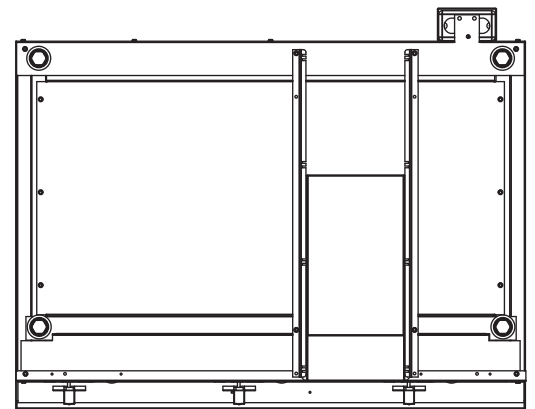
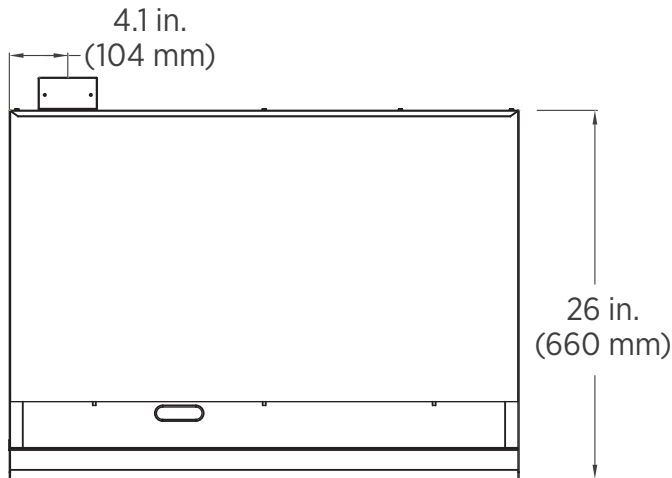

MODEL	HEIGHT	WIDTH [A]	DEPTH	APPROX. SHIP WEIGHT	APPROX. WEIGHT INSTALLED	
TMGE24	15.3 in. (389 mm)	24 in. (610 mm)	28.3 in. (719 mm)	175 lb. (79.4 kg)	147 lb. (66.7 kg)	
TMGE36	15.3 in. (389 mm)	36 in. (914 mm)	28.3 in. (719 mm)	262 lb. (118.8 kg)	221 lb. (100.2 kg)	
TMGE48	15.3 in. (389 mm)	48 in. (1.22 m)	28.3 in. (719 mm)	350 lb. (158.8 kg)	295 lb. (133.8 kg)	
MODEL	TOTAL kW	VOLTS	1Φ AMPS	3Φ AMPS L1	3Φ AMPS L2	3Φ AMPS L3
TMGE24	6/8	208/240	28.8/33.3	14.4/16.7	25/28.9	14.4/16.7
TMGE36	9/12	208/240	43.3/50	25/28.9	25/28.9	25/28.9
TMGE48	12/16	208/240	57.8/66.7	38.2/44.2	25/28.9	38.2/44.2

CLEARANCE

These models will need one [1] inch (25 mm) of clearance on the rear and sides and must be installed with the supplied legs.

Due to periodic changes in designs, methods, procedures, policies and regulations, the specifications contained in this sheet are subject to change without notice. While Star Manufacturing exercises good faith efforts to provide information that is accurate, we are not responsible for errors or omissions in information provided or conclusions reached as a result of using the specifications. By using the information provided, the user assumes all risks in connection with such use.